

Code: ASF500ZL

Z-BRACKET AND L-BRACKET ASF500ZL DAHUA

Net: 240.00 PLN Gross: 240.00 PLN

Z-bracket and L-bracket set for the ASF500A / ASF500B electromagnetic lock with load capacity of 500 kg.



SPECIFICATION

Material:	Aluminum
Application:	ASF500A
Weight:	0.93 kg
Dimensions:	265 x 70 x 42 mm - Z-bracket 185 x 120 x 60 mm - L-bracket
Manufacturer / Brand:	DAHUA
Guarantee:	3 years

PRESENTATION

Dimensions:

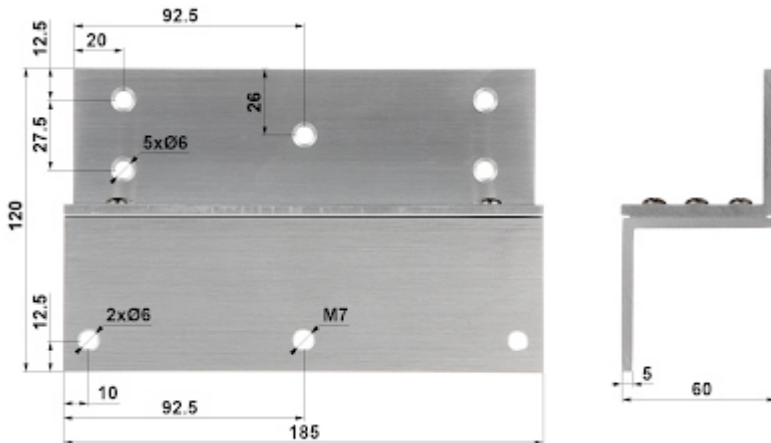

DELTA-OPTI Monika Matysiak; <https://www.delta.poznan.pl>
POL; 60-713 Poznań; Graniczna 10
e-mail: delta-opti@delta.poznan.pl; tel: +(48) 61 864 69 60

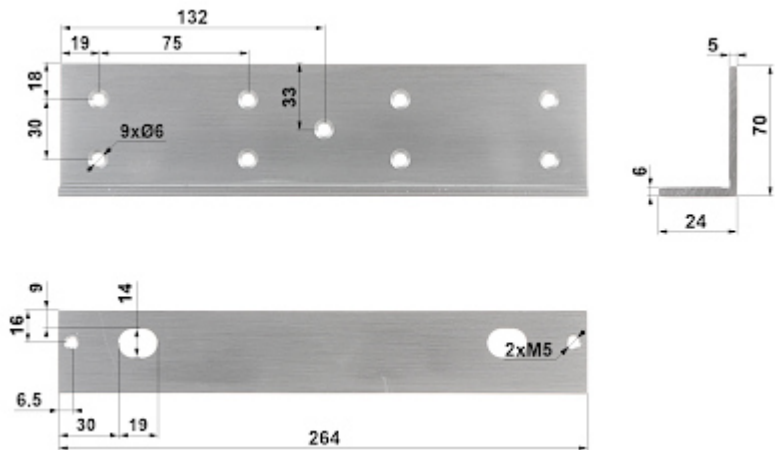

Schematic diagram:

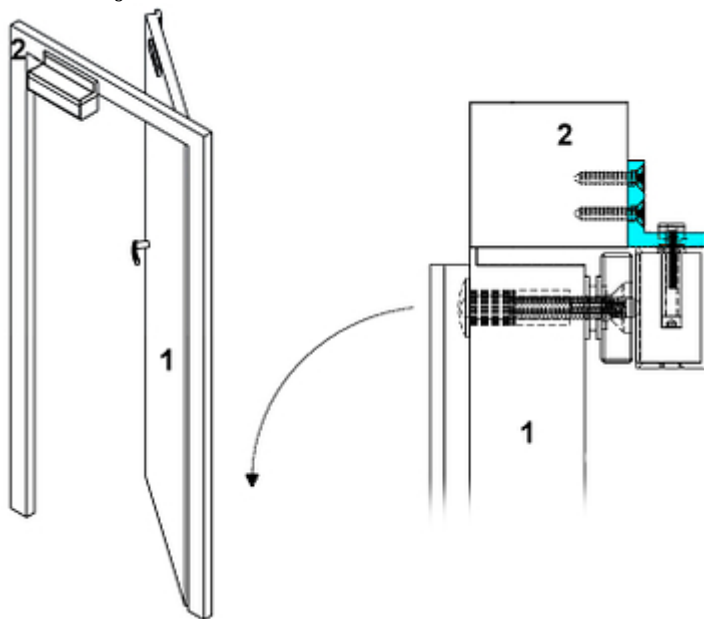

- 1. Door
 - 2. Door-frame
- In the kit:



PACKAGE

Dimensions (L x W x H): 0x0x0 mm	Gross Weight: 0 kg
----------------------------------	--------------------