

Code: XS12U-B

## ELECTRIC STRIKE **XS12U-B** Hartte BIRA

Net: **19.94 EUR** Gross: **19.94 EUR**



The Hartte electric strikes XS-series are narrow (only 16.2 mm width) and have a small dimensions enabling mounting in narrow profiles and door frames. The XS12U-B model is equipped with strengthen spring for doors with lock latch pressing on electric strikes.

They are built symmetrically - fit perfectly to left and right doors of various types. Radius latch (it is not outstanding out of electric strike outline) and adjustment in the range of 3.5 mm requires less punching, and making installation easier and quicker.

### SPECIFICATION

|                                                |                                                                                                                                                                                                                                                                                                                                                                                  |
|------------------------------------------------|----------------------------------------------------------------------------------------------------------------------------------------------------------------------------------------------------------------------------------------------------------------------------------------------------------------------------------------------------------------------------------|
| Rated voltage:                                 | 10 ... 14 V AC/DC                                                                                                                                                                                                                                                                                                                                                                |
| Current consumption:                           | 480 mA @ 12 V AC<br>680 mA @ 12 V DC                                                                                                                                                                                                                                                                                                                                             |
| Application:                                   | right-side door / left-side door - for doors with lock latch pressing on electric strikes                                                                                                                                                                                                                                                                                        |
| Ratched lock:                                  | —                                                                                                                                                                                                                                                                                                                                                                                |
| Memory function:                               | —                                                                                                                                                                                                                                                                                                                                                                                |
| Reverse action:                                | —                                                                                                                                                                                                                                                                                                                                                                                |
| Clearance adjustment:                          | 3.5 mm                                                                                                                                                                                                                                                                                                                                                                           |
| Allowable load of the door impacting the lock: | 3000 N                                                                                                                                                                                                                                                                                                                                                                           |
| Allowable uninterrupted operation time:        | —                                                                                                                                                                                                                                                                                                                                                                                |
| Main features:                                 | <ul style="list-style-type: none"><li>• Symmetrical housing</li><li>• Narrow profile : 16.2 mm,</li><li>• Strengthen spring,</li><li>• Operation mode : NC</li><li>• Resistance : 17.6 <math>\Omega</math></li><li>• Number of opening cycles : 200000</li><li>• Radial shape of the latch - when opening the latch is not going beyond the outline of electric strike</li></ul> |
| Weight:                                        | 0.136 kg                                                                                                                                                                                                                                                                                                                                                                         |
| Dimensions:                                    | 16.2 x 28 x 67 mm                                                                                                                                                                                                                                                                                                                                                                |
| Manufacturer / Brand:                          | BIRA                                                                                                                                                                                                                                                                                                                                                                             |

DELTA-OPTI Monika Matysiak; <https://www.delta.poznan.pl>  
POL; 60-713 Poznań; Graniczna 10  
e-mail: [delta-opti@delta.poznan.pl](mailto:delta-opti@delta.poznan.pl); tel: +(48) 61 864 69 60

Guarantee:

2 years

## PRESENTATION



Connectors:

DELTA-OPTI Monika Matysiak; <https://www.delta.poznan.pl>  
POL; 60-713 Poznań; Graniczna 10  
e-mail: [delta-opti@delta.poznan.pl](mailto:delta-opti@delta.poznan.pl); tel: +(48) 61 864 69 60



Dimensions:

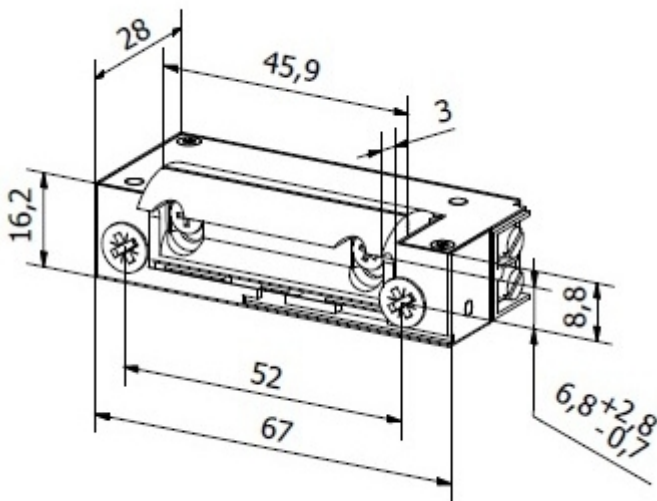

Determination of the left- and right side doors:

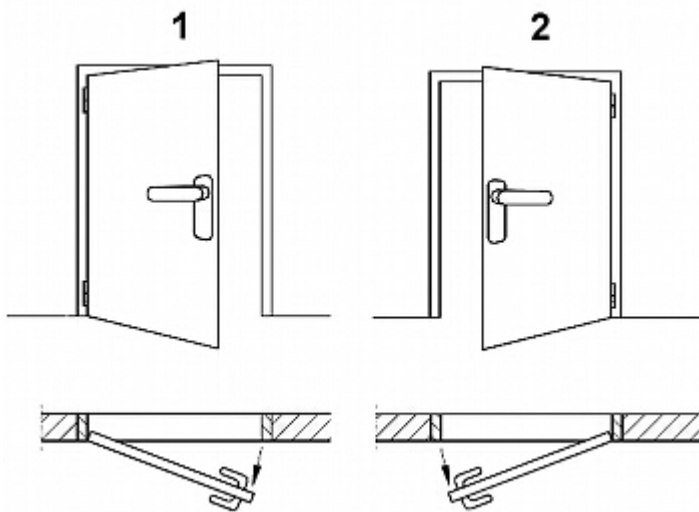

- 1). right-side door
- 2). left-side door

**PACKAGE**



DELTA-OPTI Monika Matysiak; <https://www.delta.poznan.pl>  
 POL; 60-713 Poznań; Graniczna 10  
 e-mail: delta-opti@delta.poznan.pl; tel: +(48) 61 864 69 60

|                                  |                    |
|----------------------------------|--------------------|
| Dimensions (L x W x H): 0x0x0 mm | Gross Weight: 0 kg |
|----------------------------------|--------------------|

