

Code: DS-2CE16D8T-ITE(2.8mm)

HD-TVI CAMERA **DS-2CE16D8T-ITE(2.8mm)** - 1080p PoC.af Hikvision

Net: **69.18 EUR** Gross: **69.18 EUR**

Megapixel camera with Progressive Scan CMOS sensor and HD-TVI (High Definition Transport Video Interface).

The HD-TVI interface allows to transmission of analog video signal via coaxial cable at resolutions up to 1080p. It enables the transmission of HD resolution images for even 500 m distance with keeping the low costs of the installation. During transmission there are no delays and is maintained the original, high quality image.

The 3-Axis integrated camera bracket has a regulation in all three planes, which allows to turn the camera to any direction. Camera is according to IP67 Index of Protection norm.

The ability to power the camera via a coaxial cable according to the innovative PoC (Power over Coaxial) standard allows to eliminate the need for additional wiring to the unit.



SPECIFICATION

Standard:	HD-TVI
Sensor:	Progressive Scan CMOS
Matrix size:	2.1 Mpx
Resolution:	1920 x 1080 - 1080p
Range of IR illumination:	20 m
IR illuminator power adjustment:	Automatic
Lens:	2.8 mm
View angle:	<ul style="list-style-type: none">• 104 ° (manufacturer data)• 102 ° (our tests result)
Video output:	1 Vpp / 75 Ω - HD-TVI, BNC socket
Main features:	<ul style="list-style-type: none">• WDR - 120 dB - Wide Dynamic Range• 3D-DNR - Digital Noise Reduction• EXIR - high-efficiency infrared LEDs technology, which evenly covers the whole plan of both central vantage points of the scene as well as the corners• The ability to power the camera via a coaxial cable according to the innovative PoC (Power over Coaxial) standard allows to eliminate the need for additional wiring to the unit• Privacy zones - max. 4• Motion Detection - max. 4 zones• ICR - Movable InfraRed filter• Mirror - Mirror image• BLC - Back Light Compensation• Auto White Balance• Sharpness - sharper image outlines
OSD menu:	OSD menu available via Hikvision HD-TVI recorder
Power supply:	12 V DC / 300 mA , PoC.af

Power consumption:	≤ 3.6 W
Housing:	Compact, Metal
Color:	White / Black
"Index of Protection":	IP67
Operation temp:	-40 °C ... 60 °C
Weight:	0.374 kg
Dimensions:	Ø 70 x 163 mm
Supported languages:	English
Manufacturer / Brand:	Hikvision
SAP Code:	300508192
Guarantee:	3 years

PRESENTATION



Side view:



Mounting side view:



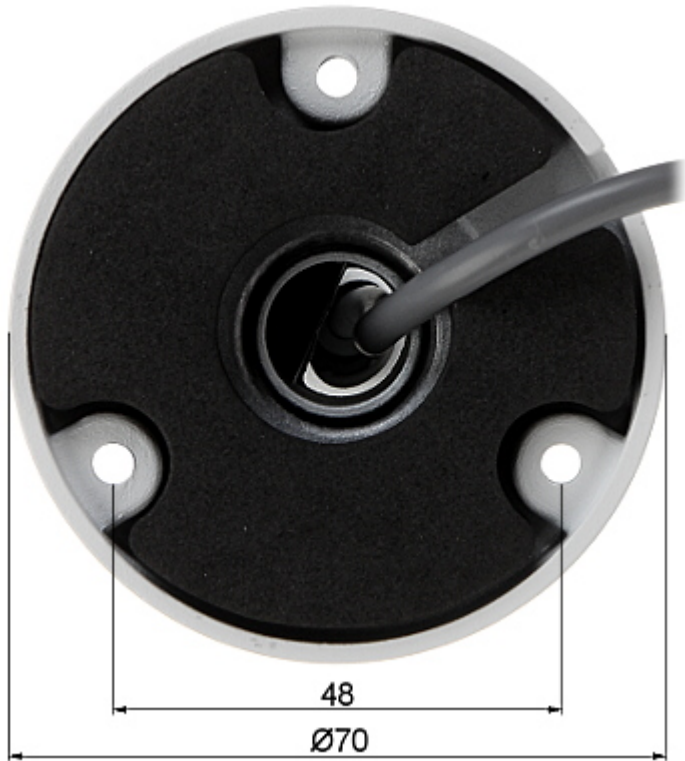

Camera dimensions:

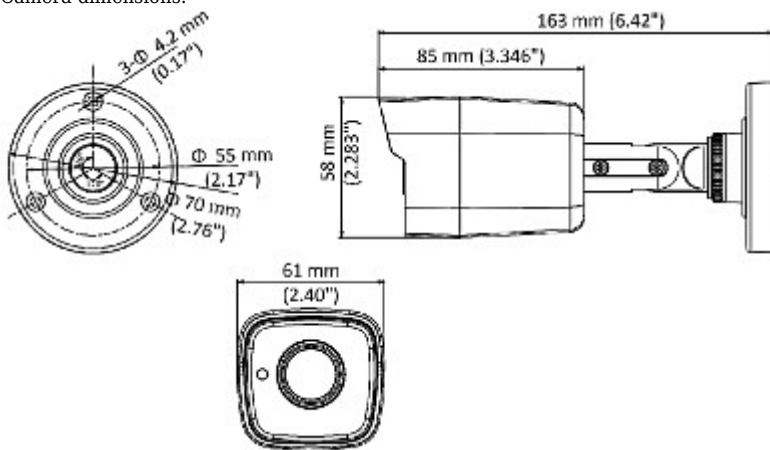

In the kit:



OUR TESTS

Camera image at artificial illumination (about 30Lux):



Camera image at night conditions with internal built-in IR illuminator on:



Camera image at direct strong light opposite to camera:

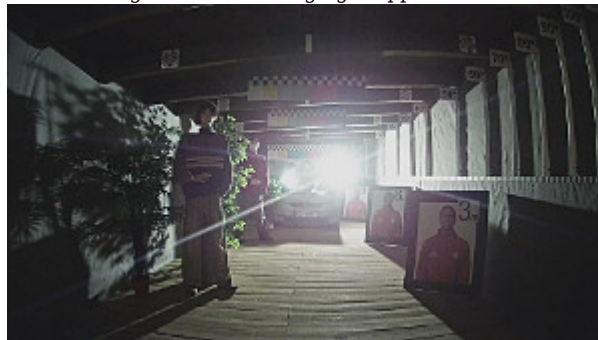

PACKAGE

Dimensions (L x W x H): 0x0x0 mm	Gross Weight: 0 kg
----------------------------------	--------------------