

Code: DS-2CE16H1T-IT5(6MM)

## HD-TVI CAMERA **DS-2CE16H1T-IT5(6MM)** - 5.0 Mpx Hikvision

Net: **37 142.86 HUF** Gross: **37 142.86 HUF**

Megapixel camera with Progressive Scan CMOS sensor and HD-TVI (High Definition Transport Video Interface). The HD-TVI interface allows to transmission of analog video signal via coaxial cable at resolutions up to 5.0 Mpx. It enables the transmission of HD resolution images for even 500 m distance with keeping the low costs of the installation. During transmission there are no delays and is maintained the original, high quality image. The 3-Axis integrated camera bracket has a regulation in all three planes, which allows to turn the camera to any direction. Camera is according to IP67 Index of Protection norm.



### SPECIFICATION

Standard:	HD-TVI
Sensor:	Progressive Scan CMOS
Matrix size:	5.0 Mpx
Resolution:	2592 x 1944 - 5.0 Mpx @ 20 fps, 12.5 fps , 2560 x 1440 - 4.0 Mpx @ 30 fps, 25 fps 1920 x 1080 - 1080p @ 30 fps, 25 fps
Range of IR illumination:	80 m
IR illuminator power adjustment:	Automatic
Lens:	6 mm
View angle:	• 46 ° (manufacturer data) • 48 ° (our tests result)
S/N ratio:	> 62 dB
Video output:	1 Vpp / 75 Ω - HD-TVI, BNC socket
Main features:	<ul style="list-style-type: none"><li>• DNR - Digital Noise Reduction</li><li>• EXIR - high-efficiency infrared LEDs technology, which evenly covers the whole plan of both central vantage points of the scene as well as the corners</li><li>• ICR - Movable InfraRed filter</li><li>• Mirror - Mirror image</li><li>• BLC - Back Light Compensation</li><li>• AGC - Automatic Gain Control</li><li>• Auto White Balance</li><li>• Sharpness - sharper image outlines</li></ul>
OSD menu:	OSD menu available via Hikvision HD-TVI recorder
Power supply:	12 V DC / 416 mA
Power consumption:	≤ 5 W
Housing:	Compact, Metal

DELTA-OPTI Monika Matysiak; <https://www.delta.poznan.pl>  
POL; 60-713 Poznań; Graniczna 10  
e-mail: [delta-opti@delta.poznan.pl](mailto:delta-opti@delta.poznan.pl); tel: +(48) 61 864 69 60

Color:	White / Black
"Index of Protection":	IP67
Operation temp:	-40 °C ... 60 °C
Weight:	0.58 kg
Dimensions:	226 x 87 x 82 mm
Supported languages:	English
Manufacturer / Brand:	Hikvision
SAP Code:	300507857
Guarantee:	<b>3 years</b>

## PRESENTATION



Side view:



Mounting side view:

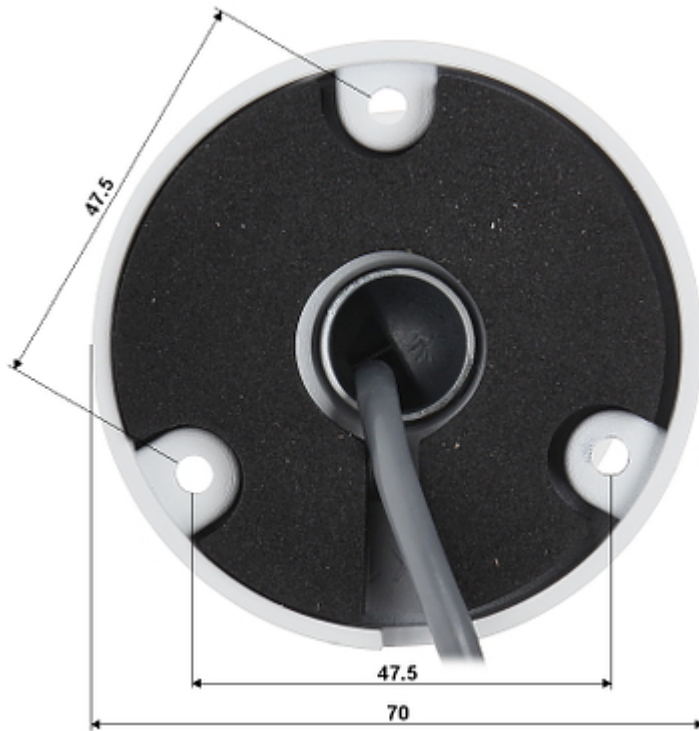

Camera and bracket dimensions:

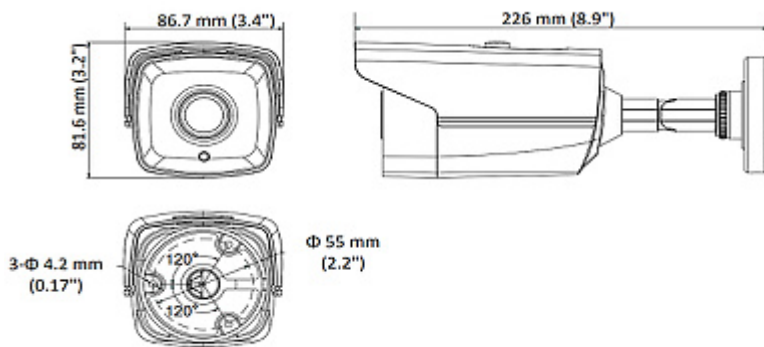

In the kit:



**OUR TESTS**



DELTA-OPTI Monika Matysiak; <https://www.delta.poznan.pl>  
 POL; 60-713 Poznań; Graniczna 10  
 e-mail: delta-opti@delta.poznan.pl; tel: +(48) 61 864 69 60

Camera image at artificial illumination (about 30Lux):



Camera image at night conditions with internal built-in IR illuminator on:



Camera image at direct strong light opposite to camera:



## PACKAGE

Dimensions (L x W x H): 0x0x0 mm	Gross Weight: 0 kg
----------------------------------	--------------------