

Code: DS-2CE17U8T-IT(2.8MM)

HD-TVI, PAL CAMERA **DS-2CE17U8T-IT(2.8MM)** - 8.3 Mpx Hikvision

Net: 6 087.48 CZK Gross: 6 087.48 CZK

Megapixel camera with Progressive Scan CMOS sensor and HD-TVI (High Definition Transport Video Interface).

The HD-TVI interface allows to transmission of analog video signal via coaxial cable at resolutions up to max. 8.3 Mpx (4K UHD). It enables the transmission of HD resolution images for even 500 m distance with keeping the low costs of the installation. During transmission there are no delays and is maintained the original, high quality image.

The 3-Axis integrated camera bracket has a regulation in all three planes, which allows to turn the camera to any direction. Camera is according to IP67 Index of Protection norm.



SPECIFICATION

Standard:	HD-TVI, PAL
Sensor:	Progressive Scan CMOS
Matrix size:	8.3 Mpx
Resolution:	3840 x 2160 - 8.3 Mpx @ 12.5 fps , 2592 x 1944 - 5 Mpx @ 20 fps , 2560 x 1440 - 4 Mpx @ 25 fps 1920 x 1080 - 1080p @ 25 fps 960 x 576 - 960H, CVBS
Range of IR illumination:	40 m
IR illuminator power adjustment:	Automatic
Lens:	2.8 mm
View angle:	<ul style="list-style-type: none">• 102 ° (manufacturer data)• 100 ° (our tests result)
Video output:	<ul style="list-style-type: none">• 1 Vpp / 75 Ω - HD-TVI, BNC socket• 1 Vpp / 75 Ω - CVBS, BNC socket
Main features:	<ul style="list-style-type: none">• 3D-DNR - Digital Noise Reduction• WDR - 120 dB - Wide Dynamic Range• EXIR - high-efficiency infrared LEDs technology, which evenly covers the whole plan of both central vantage points of the scene as well as the corners• F-DNR (Defog) - Reduction of image noise caused by precipitation• ICR - Movable InfraRed filter• Mirror - Mirror image• BLC/HLC - Back Light / High Light Compensation• AGC - Automatic Gain Control• Privacy zones - max. 4• Auto White Balance• Sharpness - sharper image outlines
OSD menu:	OSD menu available via Hikvision HD-TVI recorder
Power supply:	12 V DC / 400 mA

DELTA-OPTI Monika Matysiak; <https://www.delta.poznan.pl>
POL; 60-713 Poznań; Graniczna 10
e-mail: delta-opti@delta.poznan.pl; tel: +(48) 61 864 69 60

Power consumption:	≤ 4.8 W
Housing:	Compact, Metal
Color:	White
"Index of Protection":	IP67
Operation temp:	-40 °C ... 60 °C
Weight:	0.42 kg
Dimensions:	Ø 70 x 160 mm
Supported languages:	English
Manufacturer / Brand:	Hikvision
SAP Code:	300509272
Guarantee:	3 years

PRESENTATION



Side view:



Mounting side view:



Camera and bracket dimensions:

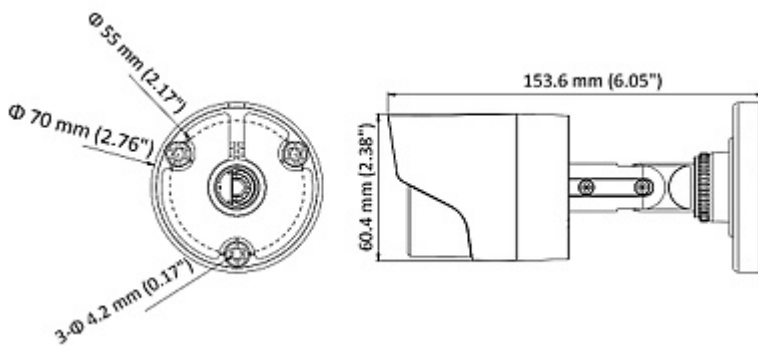

In the kit:



OUR TESTS

DELTA-OPTI Monika Matysiak; <https://www.delta.poznan.pl>
POL; 60-713 Poznań; Graniczna 10
e-mail: delta-opti@delta.poznan.pl; tel: +(48) 61 864 69 60

Camera image at artificial illumination (about 30Lux):



Camera image at night conditions with internal built-in IR illuminator on:



Camera image at direct strong light opposite to camera:



PACKAGE

Dimensions (L x W x H): 0x0x0 mm	Gross Weight: 0 kg
----------------------------------	--------------------