

Code: DS-2CE16H0T-IT3E(2.8mm)

HD-TVI CAMERA **DS-2CE16H0T-IT3E(2.8mm)** - 5 Mpx PoC.af Hikvision

Net: **80.54 EUR** Gross: **80.54 EUR**

Megapixel camera with Progressive scan CMOS sensor and HD-TVI.

The HD-TVI interface allows to transmission of analog video signal via coaxial cable at resolutions up to max. 8.3 Mpx (4K UHD). During transmission there are no delays and is maintained the original, high quality image. In the case of video transmission using a twisted pair cable and matching transformers (balun), be aware of the possibility of signal reflections and interfering signals.

The 3-Axis integrated camera bracket has a regulation in all three planes, which allows to turn the camera to any direction. Camera is according to IP67 Index of Protection norm.

The ability to power the camera via a coaxial cable according to the innovative PoC (Power over Coaxial) standard allows to eliminate the need for additional wiring to the unit.



SPECIFICATION

Standard:	HD-TVI
Sensor:	Progressive Scan CMOS
Matrix size:	5.0 Mpx
Resolution:	<ul style="list-style-type: none">• 2560 x 1944 - 5 Mpx,• 2560 x 1440 - 4 Mpx,• 1920 x 1080 - 1080p
Lens:	2.8 mm
View angle:	<ul style="list-style-type: none">• 86 ° (manufacturer data)• 81 ° (our tests result)
Range of IR illumination:	40 m
IR illuminator power adjustment:	Automatic
Video output:	1 Vpp / 75 Ω - HD-TVI, BNC socket
OSD menu:	OSD menu available via recorder
Main features:	<ul style="list-style-type: none">• D-WDR - Wide Dynamic Range• 2D-DNR - Digital Noise Reduction• EXIR - high-efficiency infrared LEDs technology, which evenly covers the whole plan of both central vantage points of the scene as well as the corners• ICR - Movable InfraRed filter• Mirror - Mirror image• BLC - Back Light Compensation• AGC - Automatic Gain Control• Auto White Balance• Sharpness - sharper image outlines
Power supply:	PoC.af , 12 V DC / 360 mA
Power consumption:	≤ 5.4 W
Housing:	Compact, Metal + Plastic

DELTA-OPTI Monika Matysiak; <https://www.delta.poznan.pl>
POL; 60-713 Poznań; Graniczna 10
e-mail: delta-opti@delta.poznan.pl; tel: +(48) 61 864 69 60

Color:	White + Black
"Index of Protection":	IP67
Operation temp:	-40 °C ... 60 °C
Weight:	0.61 kg
Dimensions:	226 x 87 x 82 mm
Supported languages:	English
Manufacturer / Brand:	Hikvision
SAP Code:	300510001
Guarantee:	3 years

PRESENTATION



Side view:



Camera dimensions:

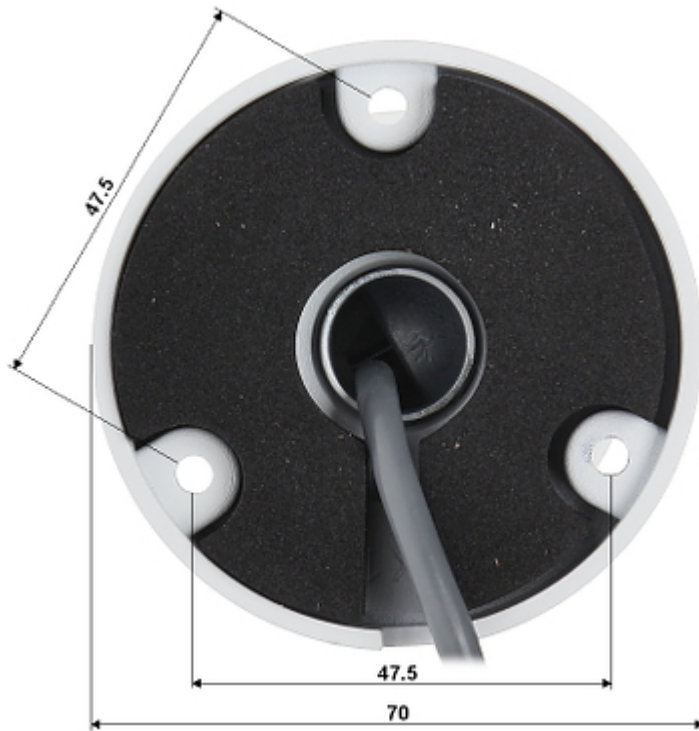

Mounting side view:

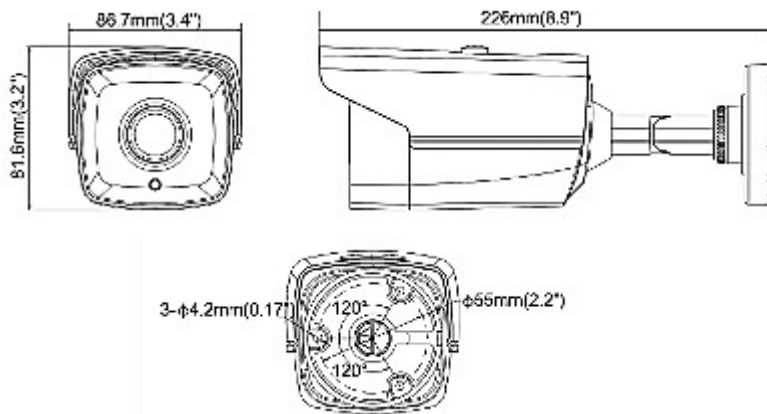

In the kit:



OUR TESTS

Camera image at artificial illumination (about 30Lux):



Camera image at night conditions with internal built-in IR illuminator on:



Camera image at direct strong light opposite to camera:



PACKAGE

Dimensions (L x W x H): 0x0x0 mm	Gross Weight: 0 kg
----------------------------------	--------------------