

Code: TT-365-5G/PROTECTED

DIRECTIONAL ANTENNA **TT-365-5G/PROTECTED** TELMOR

Net: 29.27 EUR Gross: 29.27 EUR

The TT-365-5G/PROTECTED directional antenna is designed to receive DVB-T / DVB-T2 digital terrestrial television.

Some antenna parts are made from aluminum, steel construction elements are galvanized.

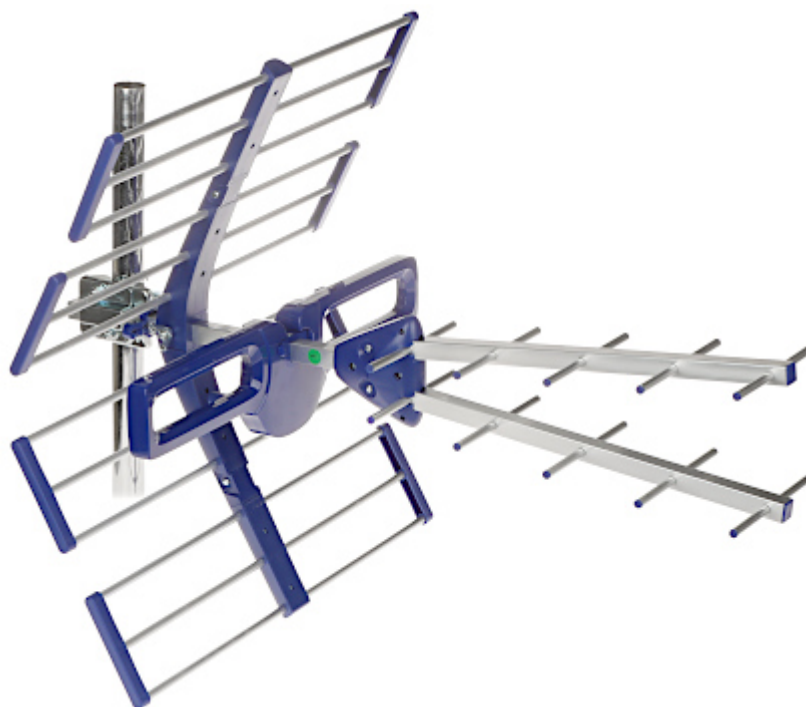

SPECIFICATION

Receiving channels:	21 ... 48
Gain :	9.5 ... 13 dBi - UHF
Frequency range:	470 ... 694 MHz
Polarization:	Horizontal
Impedance:	75 Ω
Main features:	<ul style="list-style-type: none">• Number of elements : 23• DVB-T/T2 compliance,• Built-in LTE / 5G filter• Built-in matching transformer• Weatherproof• Connector : F socket• The design of the antenna enables simple, quick assembly without the use of tools
Weight:	1.32 kg
Dimensions:	777 x 540 x 505 mm
Manufacturer / Brand:	TELMOR
Guarantee:	2 years

PRESENTATION

Mounting side view:

DELTA-OPTI Monika Matysiak; <https://www.delta.poznan.pl>
POL; 60-713 Poznań; Graniczna 10
e-mail: delta-opti@delta.poznan.pl; tel: +(48) 61 864 69 60

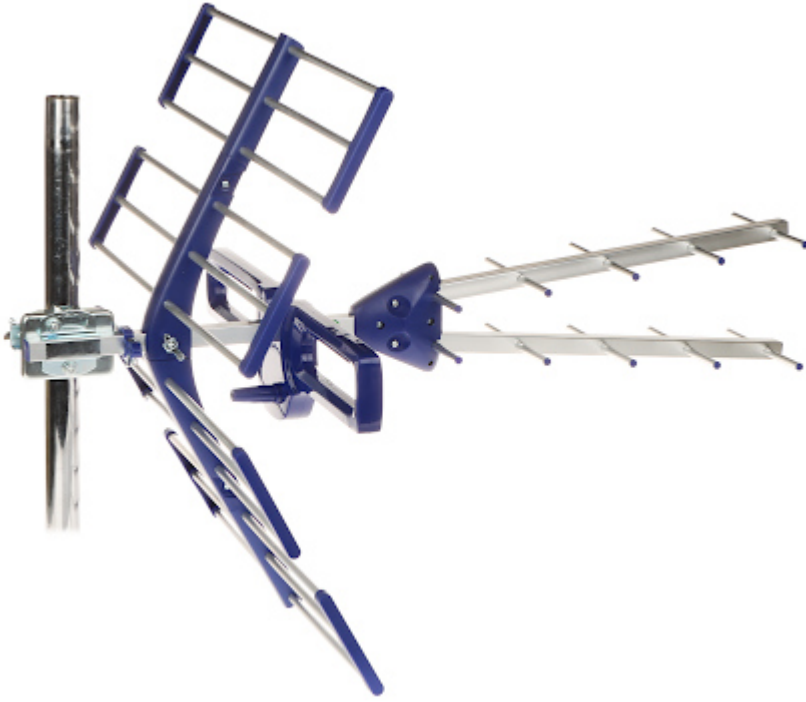

Mast mounting diameter:

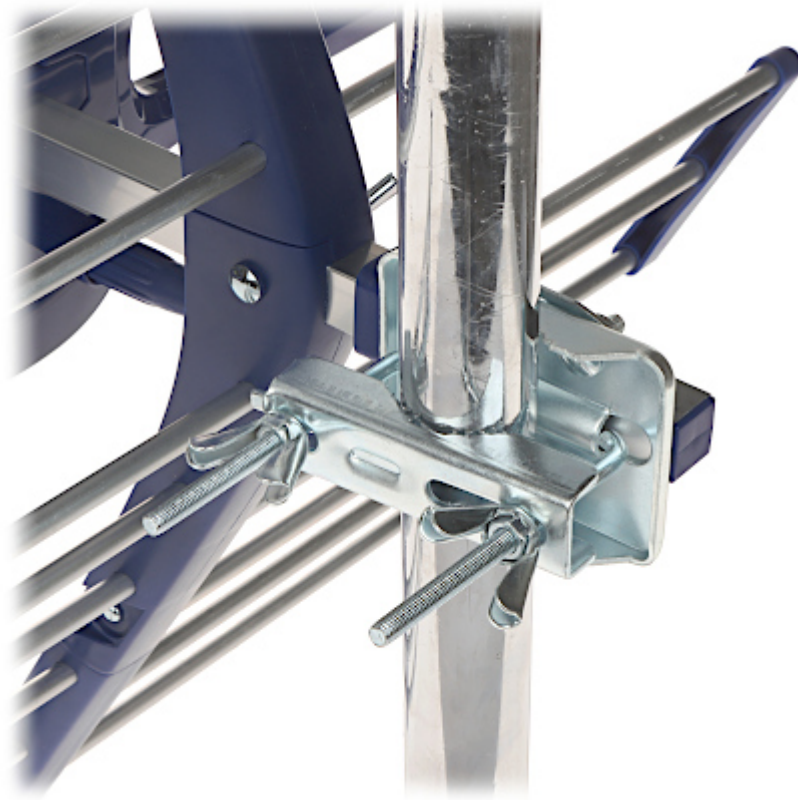



Connector:



Connector cover:

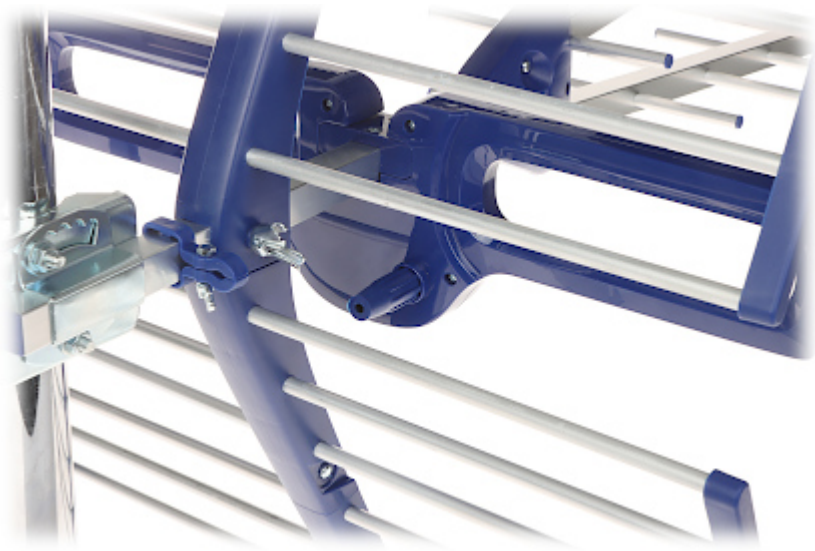

PACKAGE

Dimensions (L x W x H): 0x0x0 mm	Gross Weight: 0 kg
----------------------------------	--------------------

