

Code: UHO-S2E-M3

IP PTZ CAMERA INDOOR **UHO-S2E-M3** Wi-Fi - 3 Mpx 4 mm UNIVIEW

Net: **229.46 PLN** Gross: **229.46 PLN**



IP PTZ camera with efficient Ultra 265 image compression algorithm for clear and smooth video streaming at max. resolution of 3 MPx.

Very easy operation via mobile devices (Android / iOS), allows the users for comfortable and remote operation, and also management of the camera.

Attention! Camera for indoor use only. The TF-64G-T-L 64GB memory card included in the kit.

SPECIFICATION

Standard:	TCP/IP
Sensor:	1/3 " Progressive Scan CMOS
Matrix size:	3 Mpx
Resolution:	2304 x 1296 - 3 Mpx , 1920 x 1080 - 1080p , 1280 x 720 - 720p
Lens:	4 mm @ F2.0
View angle:	78 °
Optical zoom:	—
Digital zoom:	—
Range of IR illumination:	10 m
Preset rotation speed:	• 50 °/s (horizontal) • 50 °/s (vertical)
Rotation speed (manual control):	• 17 °/s ... 50 °/s (horizontal) • 17 °/s ... 50 °/s (vertical)
Horizontal rotation range:	0 ° ... 340 °
Vertical rotation range:	-5 ° ... 55 °
RS-485 interface:	—
Number of presets:	20



DELTA-OPTI Monika Matysiak; <https://www.delta.poznan.pl>
POL; 60-713 Poznań; Graniczna 10
e-mail: delta-opti@delta.poznan.pl; tel: +(48) 61 864 69 60

Horizontal scan:	—
Route settings:	—
Memory card slot:	Micro SD memory cards up to 256GB support (possible local recording) - The TF-64G-T-L 64GB memory card included in the kit
Image compression method:	Ultra 265 / H.265 / H.264
Alarm inputs / outputs:	—
Audio:	<ul style="list-style-type: none"> • Microphone built-in, • Speaker built-in, • Bi-directional audio streaming support, • Audio transmission via network, • Audio detection
Main stream frame rate:	25 fps @ 3 Mpx
Network interface:	<ul style="list-style-type: none"> • Wi-Fi - 2.4 GHz IEEE 802.11 b/g/n, • 10/100 Base-T (RJ-45)
WEB Server:	Built-in
ONVIF:	—
Mobile phones support:	<p>Access by a cloud (P2P)</p> <ul style="list-style-type: none"> • Android: Free application EZView • iOS (iPhone): Free application EZView
Default IP address:	DHCP or 192.168.1.13
Default admin user / password:	admin / 123456
Web browser access ports:	80, 554
PC client access ports:	Port no.: 80 or access by a cloud (P2P) - PC: Free application EZStation
Mobile client access ports:	80
Port ONVIF:	—
RTSP URL:	<p>rtsp://192.168.1.13:554/unicast/c1/s0/live - Main stream</p> <p>rtsp://192.168.1.13:554/unicast/c1/s1/live - Sub stream</p>
Main features:	<ul style="list-style-type: none"> • Wi-Fi Module • Day/night mode • ICR - Movable InfraRed filter • WB - White Balance (ATW/AWB/manual/indoor/outdoor) • AGC - Automatic Gain Control • D-WDR - Wide Dynamic Range • 2D-DNR, 3D-DNR - Digital Noise Reduction • F-DNR (Defog) - Reduction of image noise caused by precipitation • ROI - improve the quality of selected parts of image • ANR - Automatic Network Replenishment allows to save image to the card when the network connection with DVR is break (network failure) and next synchronize its • Possibility to change the resolution, quality and bit rate • Privacy zones - max. 4 • Motion Detection • Intelligent image analysis : Human detection • Automatic tracking of moving objects
Housing:	Plastic
Color:	White + Black
"Index of Protection":	—
Vandal-proof:	—
Power supply:	5 V DC / 1.5 A via micro USB port USB A / micro USB B cable included
Operation temp:	-10 °C ... 55 °C
Weight:	0.18 kg
Dimensions:	Ø 80 x 120 mm



Supported languages:	English
Manufacturer / Brand:	UNIVIEW
Guarantee:	3 years

PRESENTATION

Rear view:



Camera connectors:



Bottom view:



DELTA-OPTI Monika Matysiak; <https://www.delta.poznan.pl>
POL; 60-713 Poznań; Graniczna 10
e-mail: delta-opti@delta.poznan.pl; tel: +(48) 61 864 69 60



Camera dimensions:

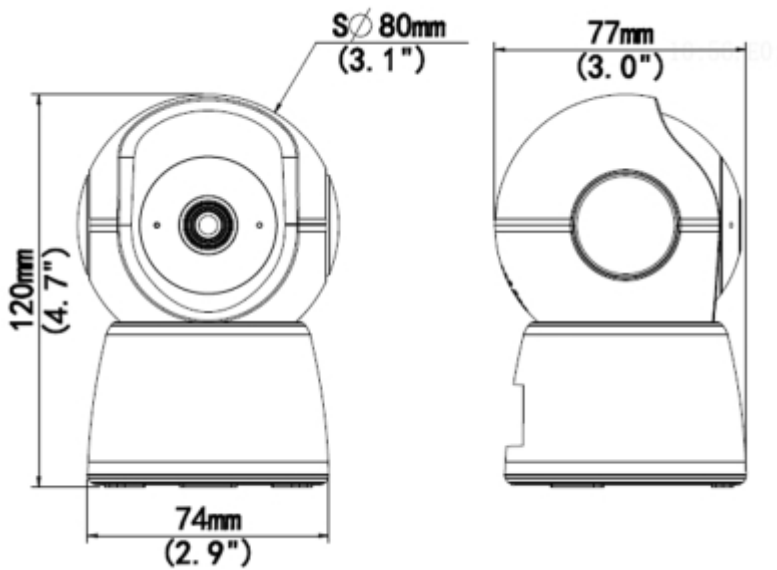

In the kit:



DELTA-OPTI Monika Matysiak; <https://www.delta.poznan.pl>
POL; 60-713 Poznań; Graniczna 10
e-mail: delta-opti@delta.poznan.pl; tel: +(48) 61 864 69 60

PACKAGE

Dimensions (L x W x H): 0x0x0 mm	Gross Weight: 0 kg
----------------------------------	--------------------

