

Code: H5B

## IP PTZ CAMERA INDOOR **H5B** Hero B1 Wi-Fi - 5 Mpx 3.6 mm DAHUA

Net: 168.00 PLN Gross: 168.00 PLN

IP PTZ camera with efficient H.265 / H.264 image compression algorithm for clear and smooth video streaming at max. resolution of 5.0 Mpx.

Very easy operation via mobile devices (Android / iOS), allows the users for comfortable and remote operation, and also management of the camera. The used Wi-Fi module allows to remote communication with camera for max. distance up to 50 m. The camera has no built-in web interface, configuration only through the DMSS application.

The device is ideal for eg. as a baby monitor, with mobile image view on smartphone and possibility of bi-directional audio transmission.



### SPECIFICATION

Standard:	IP
Resolution:	2880 x 1620 - 5 Mpx
Sensor:	1/3 " Progressive Scan CMOS
Lens:	3.6 mm
View angle:	74 °
Range of IR illumination:	10 m
Horizontal rotation range:	0 ° ... 350 ° - Rotation of the head is limited by stops
Vertical rotation range:	-5 ° ... 80 °
Audio:	<ul style="list-style-type: none"><li>• Microphone built-in,</li><li>• Speakers built-in,</li><li>• Bi-directional audio streaming support</li></ul>
Image compression method:	H.265
Main stream frame rate:	25 fps @ 5 Mpx
Interface:	<ul style="list-style-type: none"><li>• 10/100 Base-T (RJ-45),</li><li>• Wi-Fi IEEE 802.11 b/g/n</li></ul>
WEB Server:	—
ONVIF:	✓
Mobile phones support:	Access by a cloud (P2P) <ul style="list-style-type: none"><li>• Android: Free application <a href="#">DMSS</a></li><li>• iOS (iPhone): Free application <a href="#">DMSS</a></li></ul>

DELTA-OPTI Monika Matysiak; <https://www.delta.poznan.pl>  
POL; 60-713 Poznań; Graniczna 10  
e-mail: [delta-opti@delta.poznan.pl](mailto:delta-opti@delta.poznan.pl); tel: +(48) 61 864 69 60

Default IP address:	DHCP
Default admin user / password:	admin / - The administrator password should be set at the first start
Web browser access ports:	—
PC client access ports:	37777
Mobile client access ports:	37777
Port ONVIF:	80
RTSP URL:	rtsp://admin:haslo@192.168.1.108:554/cam/realmonitor?channel=1&subtype=0 - Main stream rtsp://admin:haslo@192.168.1.108:554/cam/realmonitor?channel=1&subtype=1 - Sub stream
Memory card slot:	Micro SD card support up to 256GB
Main features:	<ul style="list-style-type: none"> <li>• Wi-Fi Module - IEEE 802.11 b/g/n/ax - 2.4 GHz</li> <li>• D-WDR - Wide Dynamic Range</li> <li>• Image rotation and mirror</li> <li>• Motion Detection - max. 4 zones</li> <li>• Intelligent recognition of the human figure and tracking the movement of a person</li> </ul>
Power supply:	5 V DC / 1 A (power adapter included)
Power consumption:	≤ 3.8 W
Housing:	Plastic
Color:	White
"Index of Protection":	—
Mechanical protection class:	—
Operation temp:	-10 °C ... 45 °C
Weight:	0.21 kg
Dimensions:	Ø 84 x 123 mm
Supported languages:	English, Polish
Manufacturer / Brand:	DAHUA
Guarantee:	<b>3 years</b>

## PRESENTATION

Front view:



Rear view:



Camera connectors:





Bottom view:



Dimensions:

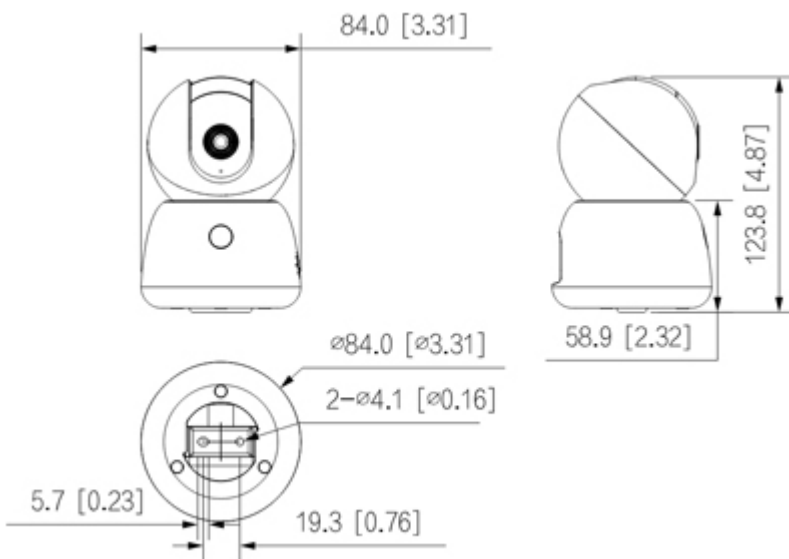

In the kit:



## OUR OPINIONS



- Very small camera dimensions.

## PACKAGE

Dimensions (L x W x H): 0x0x0 mm	Gross Weight: 0 kg
----------------------------------	--------------------