

Code: TPC-M20-B15-G

HANDHELD THERMAL MONOCULAR CAMERA **TPC-M20-B15-G** 15 mm DAHUA

Net: **742.51 EUR** Gross: **742.51 EUR**

Thermal Monocular Camera is a handheld thermal imaging camera, intended primarily for the observation of animals in their natural environments, as well as a supporting device in rescue, physical protection and hunting.

The great advantage of the thermal monocular camera is the built-in fire detection mode, which allows you to instantly locate the initial stage of a fire. Thanks to the use of a high-performance processor, the thermal monocular camera also allows you to measure the distance from the observed object (rangefinder function) using intelligent video analysis. The use of the Wi-Fi module allows for integration with the mobile application, which significantly affects the comfort of use. The device uses a built-in Li-Ion battery, which guarantees operation up to 9 hours on a single charge.



SPECIFICATION

Sensor:	Uncooled VOx microbolometer
Matrix size:	256 x 192 px
Pixel pitch:	12 µm
Display:	0.2 " LCOS, 720 x 540 px
Thermal sensitivity (NETD):	≤ 40 mK @ F1.0
Spectral range:	8 µm ... 14 µm
Color palettes:	4
Lens:	15 mm
View angle:	11.7 °
Video output:	CVBS
Memory card slot:	Micro SD memory cards up to 256GB support (possible local recording)
Image compression method:	H.265
Network interface:	Wi-Fi
Mobile phones support:	<ul style="list-style-type: none">• Android: Free application DH Thermal• iOS (iPhone): Free application DH Thermal
DRI Detection Distance:	710 m

Main features:	<ul style="list-style-type: none"> • Built-in fire detection mode, • Measure the distance from an object - rangefinder function - determining the approximate distance to the observed object based on intelligent image analysis, • Track the hottest or coldest spots in an image, • Built-in laser pointer, • Possibility to connect to an external monitor via the CVBS port - MMCX-J plug, • 4 color palettes: IRON RED - mode for long-term observations, especially at night; BLACK HOT - for observing active, moving objects - higher temperature - darker color; WHITE HOT - for observing active, moving objects - higher temperature - lighter color; ALARM - instant detection of high temperature areas, e.g. fire • Hotspot Wi-Fi • The ability to take photos, video recordings and configure parameters using a mobile application and a mobile phone, • micro USB connector (battery charging) • D-ZOOM - Digital Zoom : 2x, 3x, 4x
Battery operation time:	≤ 9 h
Typical battery charge time:	< 3 h
Power supply:	<ul style="list-style-type: none"> • Li-Ion battery, • 5 V DC / 300 mA (power adapter included)
Power consumption:	< 1.5 W
Housing:	Compact - Plastic + Rubber
Color:	Black + Gray
Operation temp:	-20 °C ... 55 °C
"Index of Protection":	IP67
Weight:	0.35 kg
Dimensions:	168.7 x 58.3 x 58.6 mm
Supported languages:	English
Manufacturer / Brand:	DAHUA
Guarantee:	3 years

PRESENTATION



Top view:



Dimensions:

mm [inch]

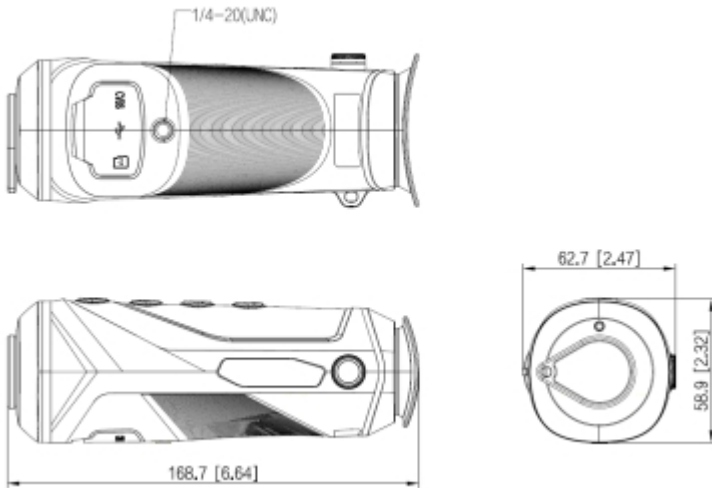

Color palettes:

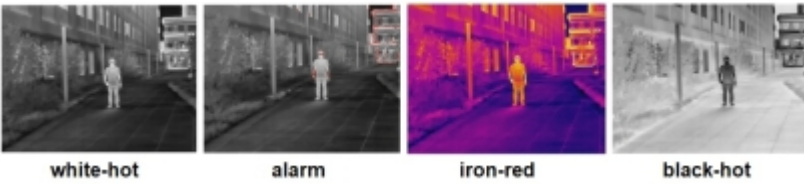

Measure the distance from an object - rangefinder function:



PACKAGE

Dimensions (L x W x H): 0x0x0 mm	Gross Weight: 0 kg
----------------------------------	--------------------

