

Code: IPC3634LB-ADZK-H

IP CAMERA **IPC3634LB-ADZK-H** - 4 Mpx 2.8 ... 12 mm - MOTOZOOM UNIVIEW

Net: **280.28 EUR** Gross: **280.28 EUR**



IP camera with efficient Ultra 265 image compression algorithm for clear and smooth video streaming at maximal resolution of 4 Mpx.

PoE powering possibility, compatible with the 802.3af standard makes the device more universal and easier to install. The range of IR illumination according to the manufacturer data, depends on outer conditions (visibility - air transparency, environment, wall colors ie. scene reflectance).

The Uniview series product has been designed to minimize costs while maintaining high quality and ease of use.

SPECIFICATION

Standard:	TCP/IP
Sensor:	1/3 " Progressive Scan CMOS
Matrix size:	4 Mpx
Resolution:	2688 x 1520 - 4 Mpx , 2560 x 1440 - 3.7 Mpx , 2304 x 1296 - 3 Mpx , 1920 x 1080 - 1080p , 1280 x 720 - 720p
Lens:	2.8 ... 12 mm - Motozoom, AutoFocus
View angle:	86 ° ... 35 °
Range of IR illumination:	40 m
RS-485 interface:	—
Memory card slot:	Micro SD memory cards up to 256GB support (possible local recording)
Image compression method:	Ultra 265 / H.265 / H.264 / MJPEG
Alarm inputs / outputs:	—
Audio:	<ul style="list-style-type: none">• Microphone built-in• Audio transmission via network• Audio detection
Main stream frame rate:	25 fps @ 4 Mpx

DELTA-OPTI Monika Matysiak; <https://www.delta.poznan.pl>
POL; 60-713 Poznań; Graniczna 10
e-mail: delta-opti@delta.poznan.pl; tel: +(48) 61 864 69 60

Network interface:	10/100 Base-TX (RJ-45)
WEB Server:	Built-in
Max. number of on-line users:	32
ONVIF:	✓
Mobile phones support:	Access by a cloud (P2P) <ul style="list-style-type: none"> • Android: Free application EZView • iOS (iPhone): Free application EZView
Default IP address:	DHCP or 192.168.1.13
Default admin user / password:	admin / 123456
Web browser access ports:	80, 554
PC client access ports:	Port no.: 80 or access by a cloud (P2P) - PC: Free application EZStation
Mobile client access ports:	80
Port ONVIF:	80
RTSP URL:	rtsp://192.168.1.13:554/unicast/c1/s0/live - Main stream rtsp://192.168.1.13:554/unicast/c1/s1/live - Sub stream
Main features:	<ul style="list-style-type: none"> • WDR - 120 dB - Wide Dynamic Range • 2D-DNR, 3D-DNR - Digital Noise Reduction • F-DNR (Defog) - Reduction of image noise caused by precipitation • ROI - improve the quality of selected parts of image • ANR - Automatic Network Replenishment allows to save image to the card when the network connection with DVR is break (network failure) and next synchronize its • NAS - Network Attached Storage support • Corridor mode - useful for monitoring corridors, entrance gates and narrow rooms • BLC/HLC - Back Light / High Light Compensation • ICR - Movable InfraRed filter • Day/night mode • Possibility to change the resolution, quality and bit rate • Motion detection with human/vehicle silhouette recognition • Privacy zones - max. 4 • Tamper signaling • Intelligent image analysis : intrusion, crossing the line (tripwire) (human silhouette)
Power supply:	<ul style="list-style-type: none"> • PoE (802.3af), • 12 V DC / 630 mA
Power consumption:	≤ 7.5 W
Housing:	Dome - Metal
Color:	White
"Index of Protection":	IP67
Vandal-proof:	—
Operation temp:	-30 °C ... 60 °C
Weight:	0.66 kg
Dimensions:	Ø 129 x 110 mm
Supported languages:	Polish, English, Czech, French, Spanish, Dutch, German, Portuguese, Slovenian, Hungarian, Italian
Manufacturer / Brand:	UNIVIEW
Guarantee:	3 years

PRESENTATION

Camera is out from clamping ring:



DELTA-OPTI Monika Matysiak; <https://www.delta.poznan.pl>
POL; 60-713 Poznań; Graniczna 10
e-mail: delta-opti@delta.poznan.pl; tel: +(48) 61 864 69 60



Memory card slot and "Reset" button:



Camera mounting side view:



Camera dimensions:

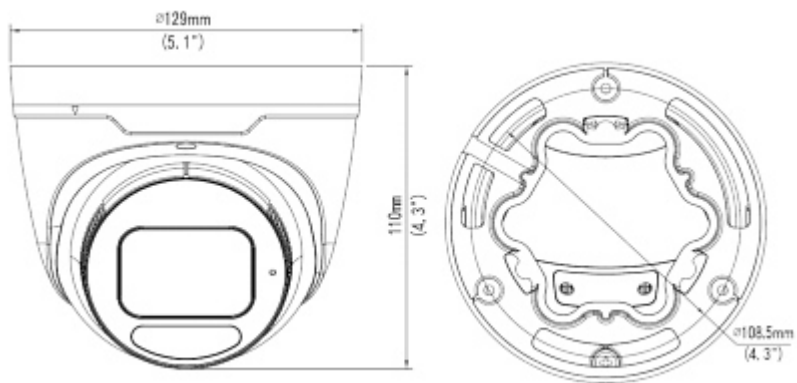

In the kit:



PACKAGE

Dimensions (L x W x H): 0x0x0 mm	Gross Weight: 0 kg
----------------------------------	--------------------



DELTA-OPTI Monika Matysiak; <https://www.delta.poznan.pl>
POL; 60-713 Poznań; Graniczna 10
e-mail: delta-opti@delta.poznan.pl; tel: +(48) 61 864 69 60