

Code: IPC3614LB-SF28K-G

## IP CAMERA **IPC3614LB-SF28K-G** - 3.7 Mpx 2.8 mm UNIVIEW

Net: **122.22 EUR** Gross: **122.22 EUR**



IP camera with efficient Ultra 265 image compression algorithm for clear and smooth video streaming at maximal resolution of 4 Mpx.

PoE powering possibility, compatible with the 802.3af standard makes the device more universal and easier to install. The range of IR illumination according to the manufacturer data, depends on outer conditions (visibility - air transparency, environment, wall colors ie. scene reflectance).

The Uniview series product has been designed to minimize costs while maintaining high quality and ease of use.

### SPECIFICATION

|                           |   |
|---------------------------|---|
| Standard:                 | TCP/IP  |
| Sensor:                   | 1/3 " Progressive Scan CMOS   |
| Matrix size:              | 4 Mpx   |
| Scanning system:          | Progressive   |
| Resolution:               | 2560 x 1440 - 3.7 Mpx ,<br>1920 x 1080 - 1080p ,<br>1280 x 720 - 720p |
| Lens:                     | 2.8 mm  |
| View angle:               | • 97 ° (manufacturer data)<br>• 90 ° (our tests result)               |
| Range of IR illumination: | 30 m  |
| S/N ratio:                | > 52 dB   |
| RS-485 interface:         | —   |
| Memory card slot:         | Micro SD memory cards up to 128GB support (possible local recording)  |
| Image compression method: | Ultra 265 / H.265 / H.264 / MJPEG                                     |
| Alarm inputs / outputs:   | —   |
| Audio:                    | —   |
| Main stream frame rate:   | 25 fps @ 3.7 Mpx  |
| Network interface:        | 10/100 Base-T (RJ-45)   |



DELTA-OPTI Monika Matysiak; <https://www.delta.poznan.pl>  
POL; 60-713 Poznań; Graniczna 10  
e-mail: [delta-opti@delta.poznan.pl](mailto:delta-opti@delta.poznan.pl); tel: +(48) 61 864 69 60

|                                |   |
|--------------------------------|---|
| Network protocols:             | IPv4, IGMP, ICMP, ARP, TCP, UDP, DHCP, RTP, RTSP, RTCP, RTMP, DNS, DDNS, NTP, FTP, UPnP, HTTP, HTTPS, SMTP, QoS, SSL / TLS, SNMP  |
| WEB Server:                    | Built-in  |
| Max. number of on-line users:  | 32  |
| ONVIF:                         | ✓   |
| Mobile phones support:         | Access by a cloud (P2P)<br><ul style="list-style-type: none"> <li>• Android: Free application <a href="#">EZView</a></li> <li>• iOS (iPhone): Free application <a href="#">EZView</a></li> </ul>  |
| Default IP address:            | DHCP or 192.168.1.13  |
| Default admin user / password: | admin / 123456  |
| Web browser access ports:      | 80, 554   |
| PC client access ports:        | Port no.: 80 or access by a cloud (P2P) - PC: Free application <a href="#">EZStation</a>  |
| Mobile client access ports:    | 80  |
| Port ONVIF:                    | 80  |
| RTSP URL:                      | rtsp://192.168.1.13:554/unicast/c1/s0/live - Main stream<br>rtsp://192.168.1.13:554/unicast/c1/s1/live - Sub stream   |
| Main features:                 | <ul style="list-style-type: none"> <li>• D-WDR - Wide Dynamic Range</li> <li>• 2D-DNR, 3D-DNR - Digital Noise Reduction</li> <li>• F-DNR (Defog) - Reduction of image noise caused by precipitation</li> <li>• ROI - improve the quality of selected parts of image</li> <li>• ANR - Automatic Network Replenishment allows to save image to the card when the network connection with DVR is break (network failure) and next synchronize its</li> <li>• NAS - Network Attached Storage support</li> <li>• BLC/HLC - Back Light / High Light Compensation</li> <li>• Possibility to change the resolution, quality and bit rate</li> <li>• Mirror - Mirror image</li> <li>• Motion Detection - max. 4 zones</li> <li>• Privacy zones - max. 4</li> <li>• Sharpness - sharper image outlines</li> </ul> |
| Power supply:                  | <ul style="list-style-type: none"> <li>• PoE (802.3af),</li> <li>• 12 V DC / 330 mA</li> </ul>  |
| Power consumption:             | ≤ 4 W   |
| Housing:                       | Dome, Metal + Plastic   |
| Color:                         | White   |
| "Index of Protection":         | IP67  |
| Vandal-proof:                  | —   |
| Operation temp:                | -30 °C ... 60 °C  |
| Weight:                        | 0.34 kg   |
| Dimensions:                    | Ø 118 x 97 mm   |
| Supported languages:           | Polish, English   |
| Manufacturer / Brand:          | UNIVIEW   |
| Guarantee:                     | <b>3 years</b>  |

## PRESENTATION

Side view:



DELTA-OPTI Monika Matysiak; <https://www.delta.poznan.pl>  
POL; 60-713 Poznań; Graniczna 10  
e-mail: [delta-opti@delta.poznan.pl](mailto:delta-opti@delta.poznan.pl); tel: +(48) 61 864 69 60



Memory card slot:



Camera is out from clamping ring:



Mounting side view:





Camera dimensions:

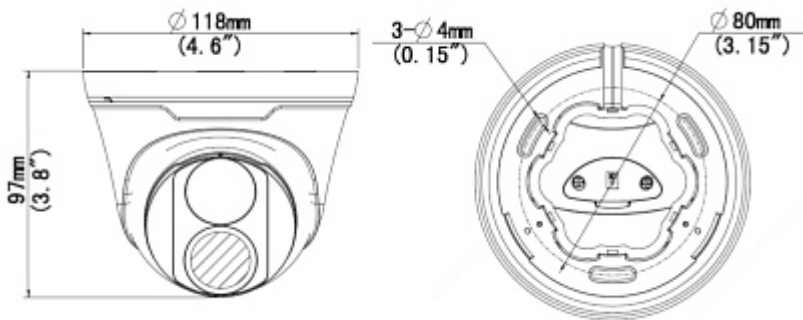

In the kit:



## OUR TESTS

Camera image at artificial illumination (about 30Lux):



Camera image at night conditions with internal built-in IR illuminator on:



Camera image at direct strong light opposite to camera:



## PACKAGE

|                                  |                    |
|----------------------------------|--------------------|
| Dimensions (L x W x H): 0x0x0 mm | Gross Weight: 0 kg |
|----------------------------------|--------------------|