

Code: BCS-DMIP1200IR-E-II

IP VANDALPROOF CAMERA **BCS-DMIP1200IR-E-II** - 1080p 3.6 mm

Net: **410.00 PLN** Gross: **410.00 PLN**



IP camera with efficient H.264 image compression algorithm for clear and smooth video streaming at maximal resolution of 1080p. Included camera software enables management and integrated monitoring of many network cameras.

ICR - The movable IR filter allows to perfect colors reproduction in daylight and wide gray-scale with high sharpness of the image at night mode.

SPECIFICATION

Standard:	TCP/IP
Sensor:	1/2.7 " Progressive Scan CMOS
Matrix size:	2.1 Mpx
Scanning system:	Progressive
Resolution:	1920 x 1080 - 1080p 1280 x 960 - 720p 1280 x 720 - 720p 704 x 576 - D1
Lens:	3.6 mm
View angle:	• 67 ° (manufacturer data) • 86 ° (our tests result)
Range of IR illumination:	20 m
S/N ratio:	> 50 dB
RS-485 interface:	—
Memory card slot:	—
Image compression method:	H.264 / MJPEG
Alarm inputs / outputs:	—
Audio:	—
Bitrate:	32 ... 8192 kbps - H.264 32 ... 12288 kbps - MJPEG
Main stream frame rate:	25 fps @ 1920 x 1080
Network interface:	10/100 Base-T (RJ-45)
Network protocols:	IPv4/IPv6, HTTP, HTTPS, SSL, TCP/IP, UDP, UPnP, ICMP, IGMP, SNMP, RTSP, RTP, SMTP, NTP, DHCP, DNS, PPPOE, DDNS, FTP, IP Filter, QoS, Bonjour

DELTA-OPTI Monika Matysiak; <https://www.delta.poznan.pl>
POL; 60-713 Poznań; Graniczna 10
e-mail: delta-opti@delta.poznan.pl; tel: +(48) 61 864 69 60

WEB Server:	Built-in
Max. number of on-line users:	20
ONVIF:	2.41
Main features:	<ul style="list-style-type: none"> • 3D-DNR - Digital Noise Reduction • D-WDR - Wide Dynamic Range • BLC/HLC - Back Light / High Light Compensation • Possibility to change the resolution, quality and bit rate • Motion Detection • Configurable Privacy Zones • Mirror - Mirror image
Vandal-proof:	✓
Color:	White
Power supply:	<ul style="list-style-type: none"> • PoE (802.3af) • 12 V DC / 280 mA
Mobile phones support:	Port no.: 37777 or access by a cloud (P2P) <ul style="list-style-type: none"> • Android: Free application DMSS • iOS (iPhone): Free application DMSS • Windows Phone: Free application wDMSS Lite There are also paid versions of mobile applications: gDMSS Plus, iDMSS Plus, wDMSS plus
Housing:	Dome - Metal
Operation temp:	-20 °C ... 55 °C
"Index of Protection":	IP66
Weight:	0.33 kg
Dimensions:	Ø 93 x 81 mm
Supported languages:	English, Polish
Manufacturer / Brand:	BCS
Guarantee:	2 years

PRESENTATION

Camera is out from clamping ring:



Mounting side view:

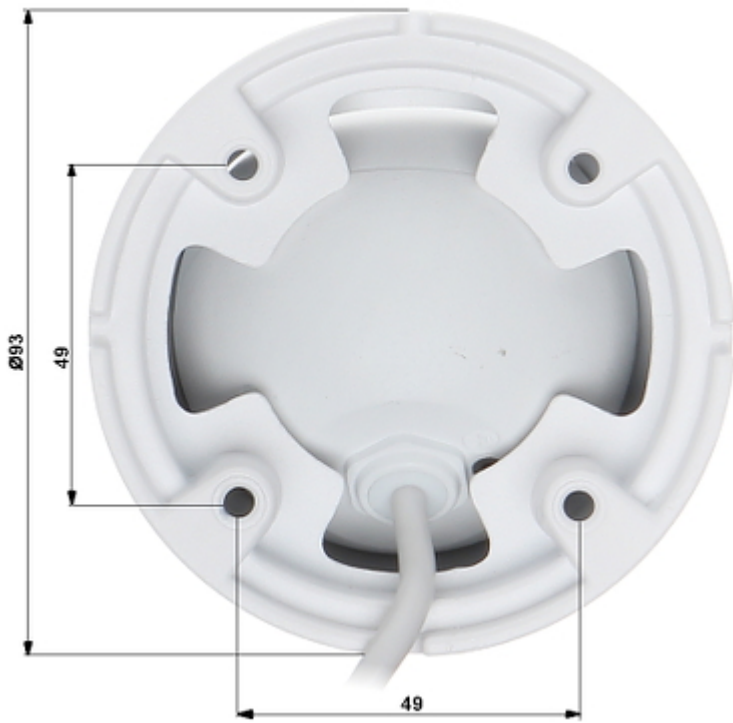

Dimensions:

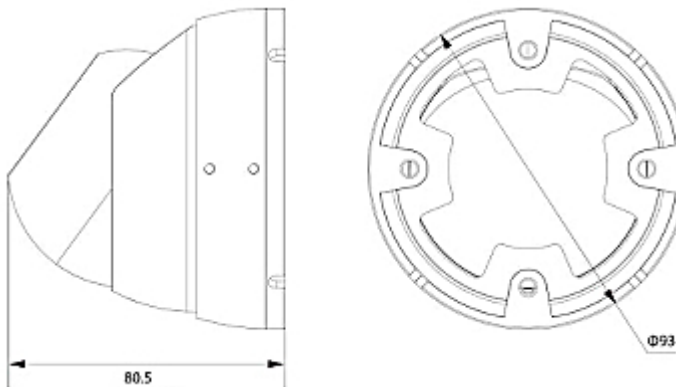

In the kit:



OUR TESTS



DELTA-OPTI Monika Matysiak; <https://www.delta.poznan.pl>
 POL; 60-713 Poznań; Graniczna 10
 e-mail: delta-opti@delta.poznan.pl; tel: +(48) 61 864 69 60

Camera image at artificial illumination (about 30Lux):



Camera image at night conditions with internal built-in IR illuminator on:



Camera image at direct strong light opposite to camera:



PACKAGE

Dimensions (L x W x H): 0x0x0 mm	Gross Weight: 0 kg
----------------------------------	--------------------