

Code: DS-2CE56H1T-ITZ(2.8-12mm)

HD-TVI CAMERA **DS-2CE56H1T-ITZ(2.8-12mm)** - 5.0 Mpx Hikvision

Net: **499.00 PLN** Gross: **499.00 PLN**

Megapixel camera with Progressive Scan CMOS sensor and HD-TVI (High Definition Transport Video Interface).

The HD-TVI interface allows to transmission of analog video signal via coaxial cable at resolutions up to 5 Mpx. It enables the transmission of HD resolution images for even 500 m distance with keeping the low costs of the installation. During transmission there are no delays and is maintained the original, high quality image.

The used motozoom lens with 2.8 ... 12 mm focal length allows to remote view angle adjustment.



SPECIFICATION

Standard:	HD-TVI
Sensor:	Progressive Scan CMOS
Matrix size:	5.0 Mpx
Resolution:	2592 x 1944 - 5.0 Mpx @ 20 fps, 12.5 fps , 2560 x 1440 - 4.0 Mpx @ 25 fps, 30 fps 1920 x 1080 - 1080p @ 25 fps, 30 fps
Range of IR illumination:	30 m
IR illuminator power adjustment:	Automatic
Lens:	2.8 ... 12 mm - Motozoom
View angle:	• 87 ° ... 27.7 ° (manufacturer data) • 90 ° ... 28 ° (our tests result)
S/N ratio:	> 52 dB
Video output:	1 x HD-TVI - BNC socket
Main features:	<ul style="list-style-type: none">• Motozoom lens• DNR - Digital Noise Reduction• EXIR - high-efficiency infrared LEDs technology, which evenly covers the whole plan of both central vantage points of the scene as well as the corners• ICR - Movable InfraRed filter• Mirror - Mirror image• BLC - Back Light Compensation• AGC - Automatic Gain Control• Day/night mode• Sharpness - sharper image outlines
OSD menu:	The OSD menu is available via the Hikvision HD-TVI recorder or the joystick placed under the dome
Power supply:	12 V DC / 375 mA
Power consumption:	≤ 4.5 W

DELTA-OPTI Monika Matysiak; <https://www.delta.poznan.pl>
POL; 60-713 Poznań; Graniczna 10
e-mail: delta-opti@delta.poznan.pl; tel: +(48) 61 864 69 60

Housing:	Dome, Plastic
Color:	White
"Index of Protection":	IP65
Operation temp:	-40 °C ... 60 °C
Weight:	0.42 kg
Dimensions:	Ø 136 x 102 mm
Supported languages:	English
Country of origin:	China
Manufacturer / Brand:	Hikvision
SAP Code:	300609648
Guarantee:	3 years

PRESENTATION

Internal view of the housing:



Mounting side view:

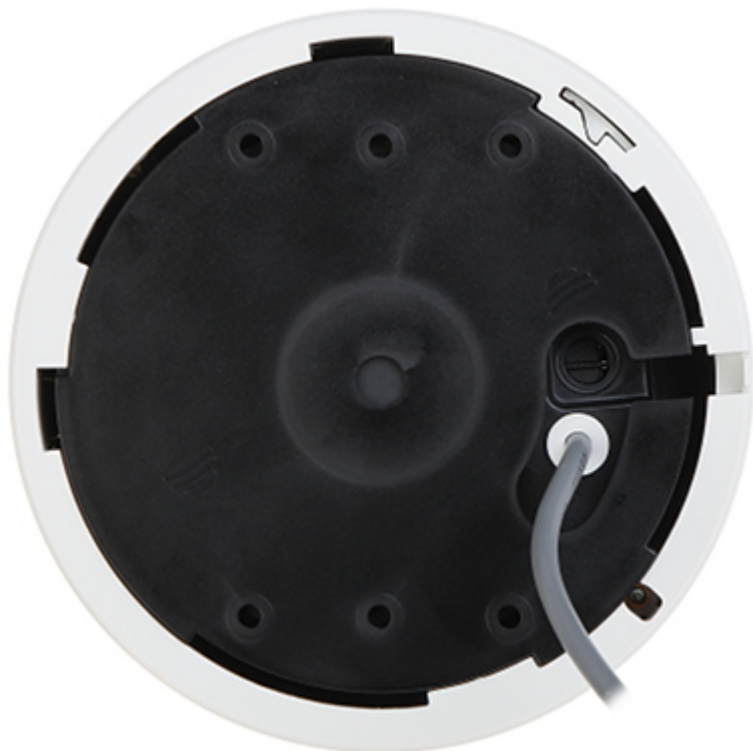

Camera dimensions:

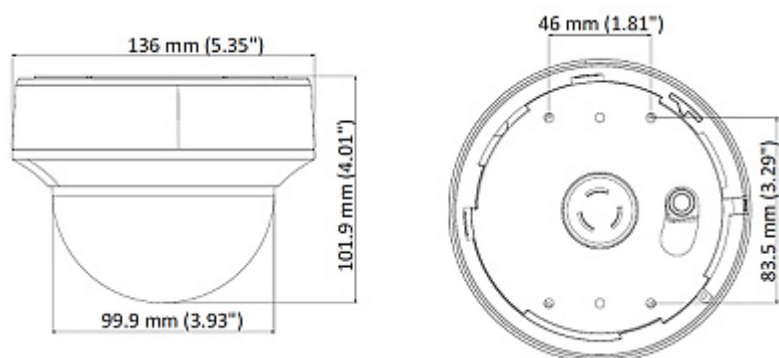

In the kit:

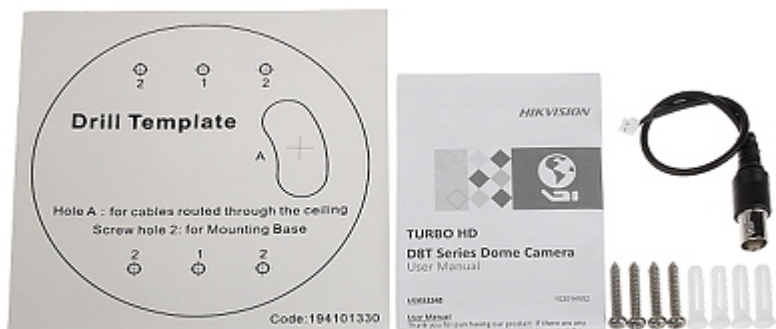

OUR TESTS

Camera image at artificial illumination (about 30Lux):



Camera image at night conditions with internal built-in IR illuminator on:



Camera image at direct strong light opposite to camera:



OUR OPINIONS



- o No function Autofocus.

PACKAGE

Dimensions (L x W x H): 0x0x0 mm	Gross Weight: 0 kg
----------------------------------	--------------------