

Code: PFA102

SPEED DOME CAMERAS ADAPTER **PFA102** DAHUA

Net: **60.00 PLN** Gross: **73.80 PLN**



Designed to Speed Dome cameras. It can be used to vandal-proof cameras installation.

SPECIFICATION

Mounting holes distance:	101 x 101 mm
Number of holes:	4
Neck diameter:	Ø 169 mm
Suitable for cameras:	DAHUA - documentation for download below.
Material:	Aluminum
Color:	White
Distance from mounting surface:	16 mm
Weight:	0.26 kg
Dimensions:	Ø 169 x 37 mm
Manufacturer / Brand:	DAHUA
Guarantee:	3 years

PRESENTATION

Camera mounting side view:

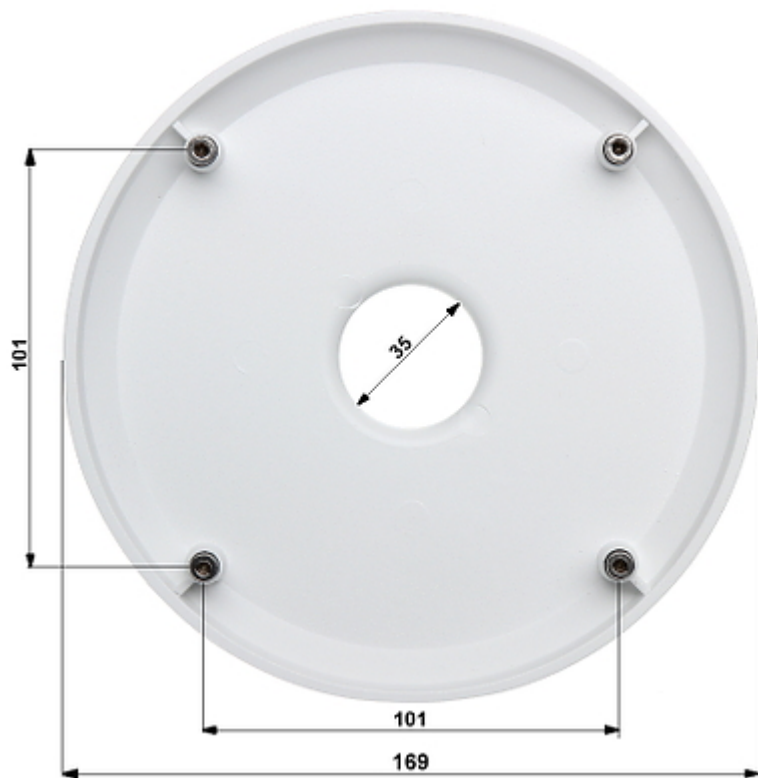

Side view:



Dimensions:

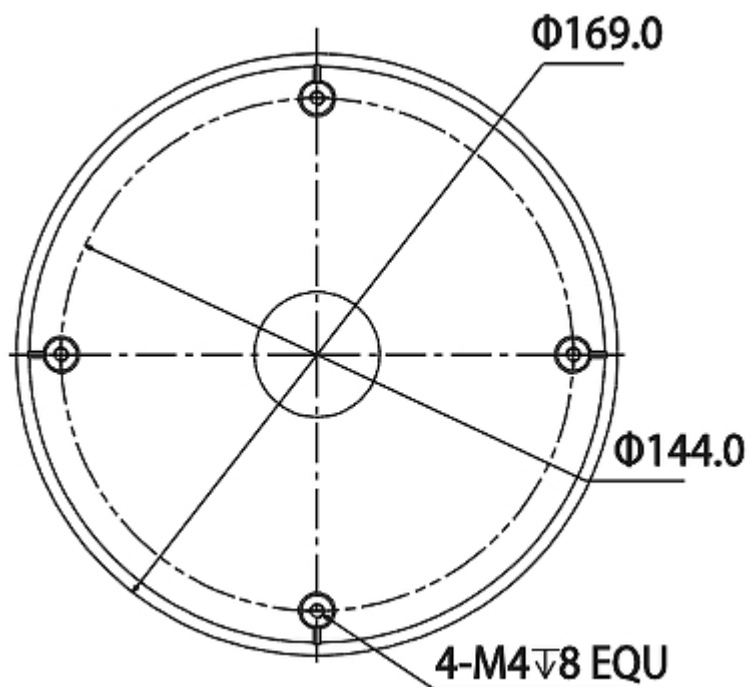

Example of application:

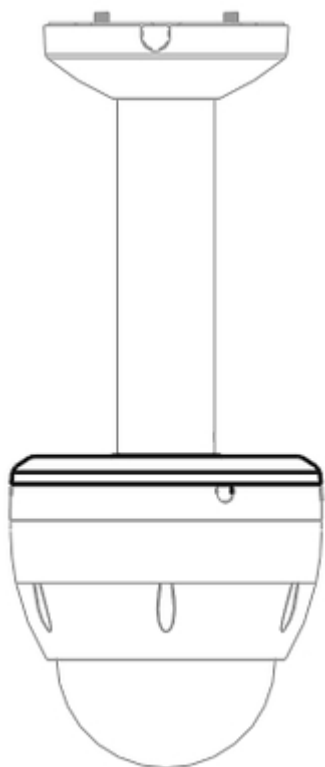

PACKAGE

Dimensions (L x W x H): 0x0x0 mm	Gross Weight: 0 kg
----------------------------------	--------------------

