

Code: SD1A404XB-GNR

IP SPEED DOME CAMERA OUTDOOR **SD1A404XB-GNR** - 3.7 Mpx 2.8 ... 12 mm DAHUA

Net: **446.74 EUR** Gross: **549.49 EUR**

IP camera equipped with very good high resolution sensor. Due to above it is perfect solution for surveillance systems requiring persons or vehicles recognition.

Built-in Infra-Red illuminator enables night monitoring. The range of IR illumination according to the manufacturer data, depends on outer conditions (visibility - air transparency, environment, wall colors ie. scene reflectance). Thanks to the "Starlight" technology used, the camera only needs very low lighting to obtain a clear color image.

For a few models of IP cameras working at $\geq 1920 \times 1080$ resolution we recommend to use of network with 1Gb/s bandwidth.



SPECIFICATION

Standard:	TCP/IP
Sensor:	1/2.8 " STARVIS™ CMOS
Matrix size:	4 Mpx
Resolution:	2560 x 1440 - 3.7 Mpx , 2048 x 1536 - 3 Mpx , 1920 x 1080 - 1080p , 1280 x 960 - 1.3 Mpx 1280 x 720 - 720p
Lens:	2.8 ... 12 mm
View angle:	• 97 ° ... 31.6 ° (manufacturer data) • 90 ° ... 43 ° (our tests result)
Optical zoom:	x 4
Digital zoom:	— x 16
Range of IR illumination:	15 m
Video output:	—
Rotation speed (manual control):	• 0.1 °/s ... 70 °/s (horizontal) • 0.1 °/s ... 30 °/s (vertical)
Preset rotation speed:	• 80 °/s (horizontal) • 40 °/s (vertical)
Horizontal rotation range:	0 ° ... 355 ° - Rotation of the head is limited by stops
Vertical rotation range:	5 ° ... 90 °
RS-485 interface:	—
Number of presets:	300

DELTA-OPTI Monika Matysiak; <https://www.delta.poznan.pl>
POL; 60-713 Poznań; Graniczna 10
e-mail: delta-opti@delta.poznan.pl; tel: +(48) 61 864 69 60

Horizontal scan:	✓
Route settings:	8
Image compression method:	H.265 / H.265+ / H.264 / H.264+ / MJPEG
Alarm inputs / outputs:	—
Main stream frame rate:	25 fps - 4 Mpx
Memory card slot:	Micro SD memory cards up to 256GB support (possible local recording)
Network interface:	10/100 Base-T (RJ-45)
Network protocols:	IPv4/IPv6, HTTP, HTTPS, IEEE 802.1x, QoS, FTP, SMTP, UPnP, SNMP, DNS, DDNS, NTP, RTSP, RTP RTCP, TCP/IP, UDP, IGMP, ICMP, DHCP, PPPoE, ARP
WEB Server:	Built-in, NVR compliance
Max. number of on-line users:	20
ONVIF:	20.06
Audio:	<ul style="list-style-type: none"> • Microphone built-in, • External microphone input, • Audio output, • Bi-directional audio streaming support • Audio detection
Mobile phones support:	Port no.: 37777 or access by a cloud (P2P) <ul style="list-style-type: none"> • Android: Free application DMSS • iOS (iPhone): Free application DMSS
Default admin user / password:	admin / - The administrator password should be set at the first start
Default IP address:	192.168.1.108
Web browser access ports:	80, 37777
PC client access ports:	37777
Mobile client access ports:	37777
Port ONVIF:	80
RTSP URL:	rtsp://admin:hasło@192.168.1.108:554/cam/realmonitor?channel=1&subtype=0 - Main stream rtsp://admin:hasło@192.168.1.108:554/cam/realmonitor?channel=1&subtype=1 - Sub stream
Main features:	<ul style="list-style-type: none"> • WDR - 120 dB - Wide Dynamic Range • 2D-DNR, 3D-DNR - Digital Noise Reduction • ROI - improve the quality of selected parts of image • F-DNR (Defog) - Reduction of image noise caused by precipitation • EIS - Electronic Image Stabilization • BLC/HLC - Back Light / High Light Compensation • ICR - Movable InfraRed filter • Day/night mode • Configurable Privacy Zones • Smart motion detection (with recognizing people and vehicles) • SMD PLUS - searching for an object classified as: human, motor vehicle • IVS analysis : intrusion, crossing the line (tripwire) - classification of people and vehicles, abandoned/missing object, video sabotage, scene changing, face detection, people counting
Power supply:	<ul style="list-style-type: none"> • PoE (802.3af), • 12 V DC / 710 mA
Power consumption:	≤ 8.5 W
Housing:	Speed Dome Metal, Plastic
Color:	Black + White
"Index of Protection":	IP66
Vandal-proof:	IK08



Operation temp:	-30 °C ... 60 °C
Weight:	0.51 kg
Dimensions:	Ø 128 x 65 mm
Supported languages:	Polish, English, Czech, French, Spanish, Dutch, German, Portuguese, Russian, Italian
Manufacturer / Brand:	DAHUA
Guarantee:	3 years

PRESENTATION

Mounting side view:



Memory card slot:



Connectors description:



Dimensions:

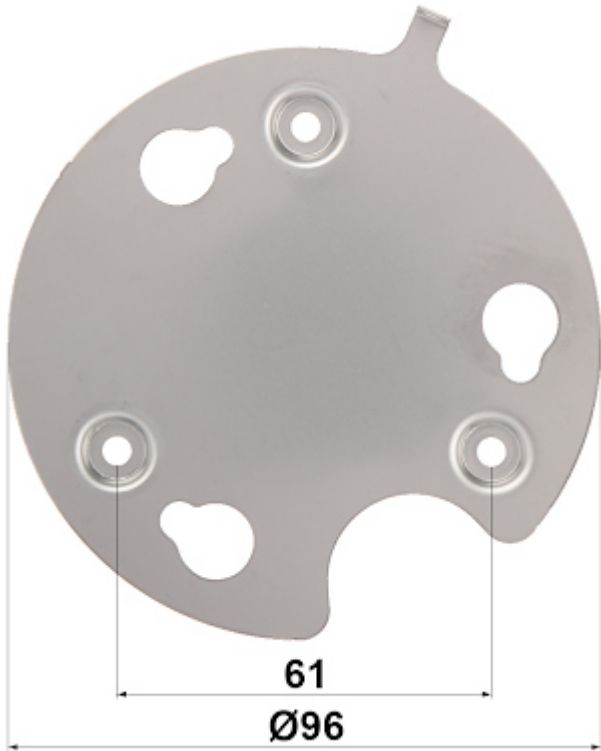
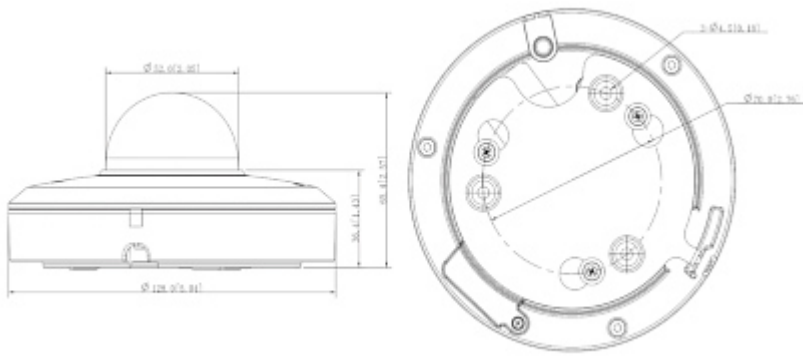

See how to initialize DAHUA cameras:

:

In the kit:



Assembly instruction:

:

OUR TESTS

Camera image at artificial illumination (about 30Lux):



DELTA-OPTI Monika Matysiak; <https://www.delta.poznan.pl>
 POL; 60-713 Poznań; Graniczna 10
 e-mail: delta-opti@delta.poznan.pl; tel: +(48) 61 864 69 60



Camera image at night conditions with internal built-in IR illuminator on:



Camera image at direct strong light opposite to camera:



OUR OPINIONS



- Thanks to the "Starlight" technology used, the camera only needs very low lighting to obtain a clear color image.

PACKAGE

Dimensions (L x W x H): 0x0x0 mm	Gross Weight: 0 kg
----------------------------------	--------------------

