

Code: BR-301TP

## HOUSING BRACKET **BR-301TP**

Net: 7.56 EUR Gross: 9.30 EUR

Aluminum, painted bracket for housings and cameras, outdoor.



### SPECIFICATION

Material:	Aluminum - powder painted
Distance from mounting surface:	260 mm
Cable hiding:	—
Color:	White
Adjustment:	in two planes
Weight:	0.37 kg
Dimensions:	300 x 84 x 125 mm
Guarantee:	2 years

### PRESENTATION

Side view:



Bracket wall mounting base dimensions:

DELTA-OPTI Monika Matysiak; <https://www.delta.poznan.pl>  
POL; 60-713 Poznań; Graniczna 10  
e-mail: delta-opti@delta.poznan.pl; tel: +(48) 61 864 69 60

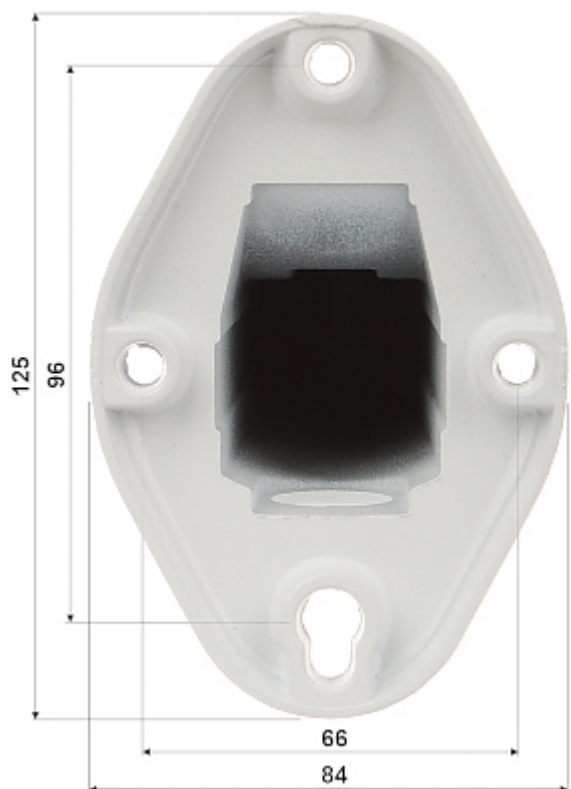

Bracket camera or housing mounting base dimensions:

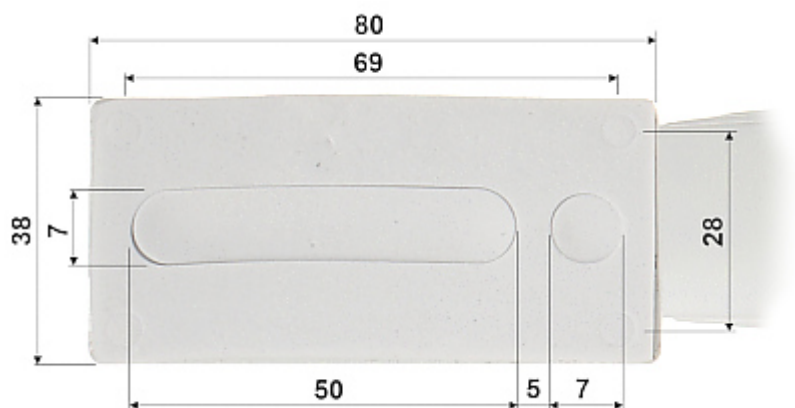

In the kit:



**PACKAGE**

Dimensions (L x W x H): 0x0x0 mm	Gross Weight: 0 kg
----------------------------------	--------------------