

Code: DS-2TP21B-6AVF/W

HANDY HYBRID THERMAL IMAGING CAMERA **DS-2TP21B-6AVF/W** 6.2 mm - 0.3 Mpx Hikvision

Net: 5 208.99 EUR Gross: 6 407.06 EUR

The DS-2TP21B-6AVF/W handy thermal imaging camera is equipped with a very sensitive, uncooled VOx microbolometer, allowing to obtain an image in the resolution of 160x120 px. The device will be perfect if you cannot permanently mount the thermal imaging camera and in mobile applications.



SPECIFICATION

| | |
|--------------------------------------|-----------------------------|
| Sensor: | Uncooled VOx microbolometer |
| Matrix size: | 160 x 120 px |
| Pixel pitch: | 17 μ m |
| Thermal sensitivity (NETD): | < 40 mK @ F1.0 |
| Spectral range: | 8 μ m ... 14 μ m |
| Color palettes: | 7 |
| Lens: | 6.2 mm |
| View angle: | 25 ° |
| Temperature measurement range: | 30 °C ... 45 °C |
| Accuracy of temperature measurement: | \pm 0.5 °C |

VIDEO CAMERA:

| | |
|------------------|-----------------------|
| Sensor: | Progressive Scan CMOS |
| Matrix size: | 0.3 Mpx |
| Scanning system: | Progressive |
| Optical zoom: | — |
| Digital zoom: | — |

DELTA-OPTI Monika Matysiak; <https://www.delta.poznan.pl>
POL; 60-713 Poznań; Graniczna 10
e-mail: delta-opti@delta.poznan.pl; tel: +(48) 61 864 69 60

| | |
|------------------------|---|
| S/N ratio: | > 50 dB (AGC off) |
| Resolution: | 640 x 480 - 0.3 Mpx |
| General information: | |
| LED illuminator: | ✓ |
| Video output: | — |
| Memory card slot: | — |
| Audio: | Microphone built-in |
| Network interface: | Wi-Fi |
| Main features: | <ul style="list-style-type: none"> • The possibility of overlapping the image from a thermal imaging camera in a classic image • PIP - Picture In Picture • Built-in 16 GB memory - photo and video local recording capability • USB C interface • Bluetooth • 3.5 " capacitive touch screen - 640 x 480 px • Temperature measurement : the warmest point, the coolest point, center of field of view of the camera, user-defined point/line/area • Adaptive AGC - Adaptive Auto Gain Control • DDE - Digital Detail Enhancement |
| Power supply: | Li-Ion battery |
| Housing: | Plastic |
| Color: | Black |
| "Index of Protection": | IP54 |
| Operation temp: | 15 °C ... 35 °C |
| Dimensions: | 244 x 104 x 100 mm |
| Weight: | 0.65 kg |
| Supported languages: | English |
| Manufacturer / Brand: | Hikvision |
| SAP Code: | 308200048 |
| Guarantee: | 3 years |

PRESENTATION

Dimensions:

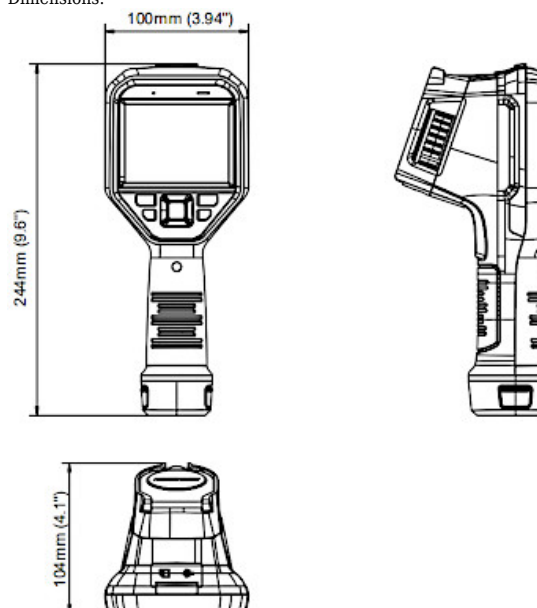

DELTA-OPTI Monika Matysiak; <https://www.delta.poznan.pl>
 POL; 60-713 Poznań; Graniczna 10
 e-mail: delta-opti@delta.poznan.pl; tel: +(48) 61 864 69 60



DELTA-OPTI Monika Matysiak; <https://www.delta.poznan.pl>
POL; 60-713 Poznań; Graniczna 10
e-mail: delta-opti@delta.poznan.pl; tel: +(48) 61 864 69 60