

Code: ATK-D2/N

# OMNIDIRECTIONAL ANTENNA **ATK-D2/N** GSM/DCS/UMTS/HSDPA TRANS-DATA

Net: **13.07 EUR** Gross: **13.07 EUR**

The ATK-D2/N indoor omnidirectional antenna used for distribution the amplified signal from GSM repeater. Compact and streamlined design makes antenna fits nicely with the surroundings.

When GSM repeater has been installed in large object, to increase the range of amplified GSM signal should be used a few indoor antennas.



## SPECIFICATION

Frequency range:	<ul style="list-style-type: none"><li>• 806 ... 960 MHz,</li><li>• 1710 ... 2500 MHz</li></ul>
Connector:	"N" Socket
Gain :	max. 3 dB
Impedance:	50 $\Omega$
Polarization:	Vertical
Main features:	Small dimensions
Weight:	0.26 kg
Dimensions:	$\varnothing$ 165 x 94 mm
Manufacturer / Brand:	TRANS-DATA
Guarantee:	2 years

## PRESENTATION

Mounting side view:



Antenna connector:



Mounting methods:

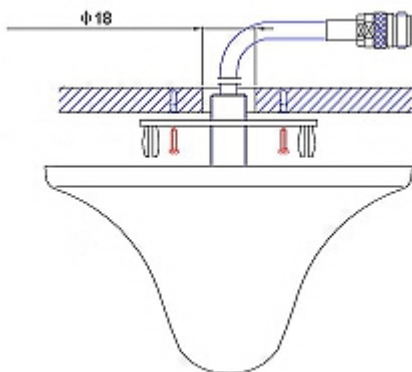

- 1) plasterboard
- 2) connector



DELTA-OPTI Monika Matysiak; <https://www.delta.poznan.pl>  
POL; 60-713 Poznań; Graniczna 10  
e-mail: [delta-opti@delta.poznan.pl](mailto:delta-opti@delta.poznan.pl); tel: +(48) 61 864 69 60

- 3) mounting accessory
- 4) screw

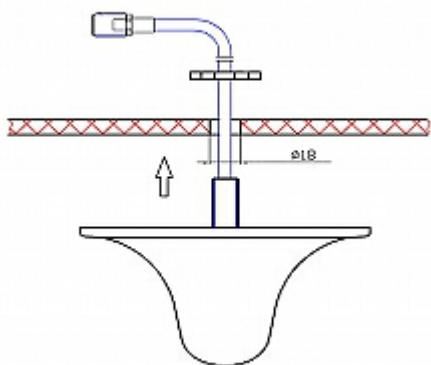

- 1) connector
- 2) nut
- 3) ceiling
- 4) internal antenna

Antenna characteristics:

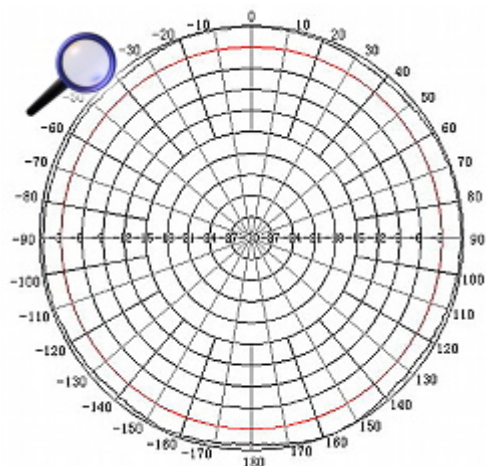
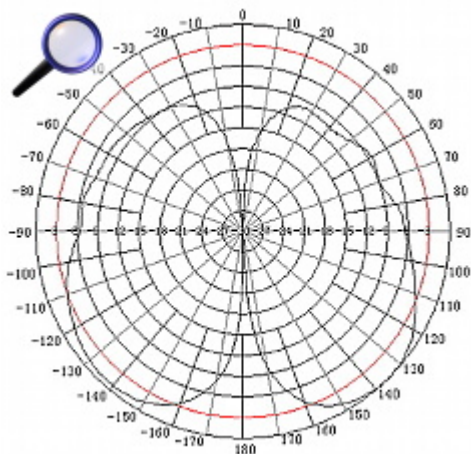

Example of application:



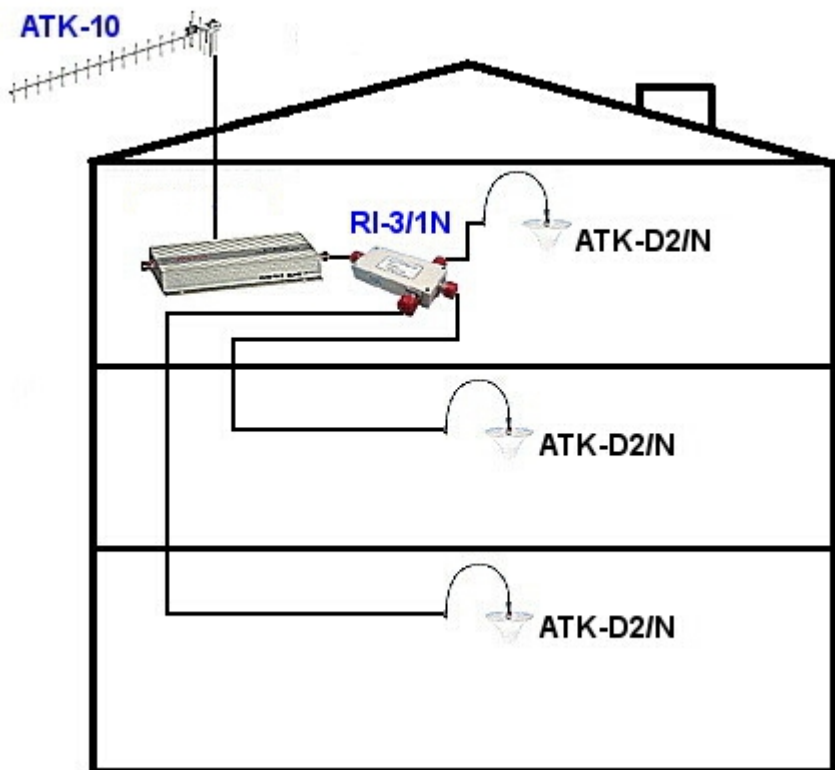

In the kit:

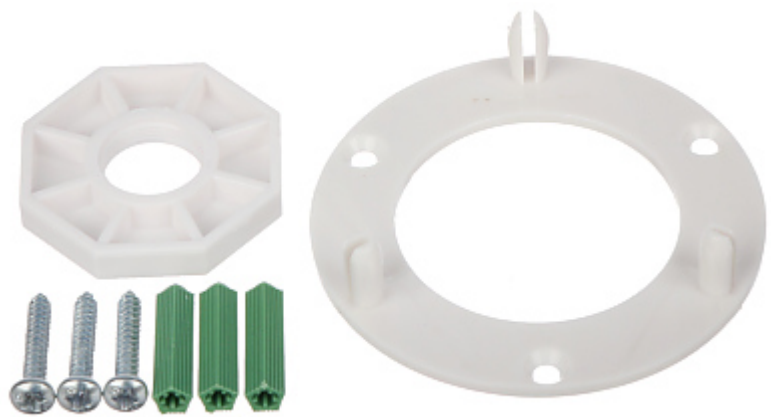

**PACKAGE**

Dimensions (L x W x H): 0x0x0 mm	Gross Weight: 0 kg
----------------------------------	--------------------