

Code: IPC-PFW8802-A180-H-E4-AC24V

IP VANDALPROOF CAMERA **IPC-PFW8802-A180-H-E4-AC24V**

PANORAMIC - 7.3 Mpx, 4 x 5.0 mm DAHUA

Net: **1 682.87 EUR** Gross: **2 069.93 EUR**

The IP camera is equipped with 4 high quality image sensors and 4 lenses with 5 mm focal length. Thanks to its unique design, the camera has a 180° viewing angle.

PoE powering possibility, compatible with the 802.3at standard makes the device more universal and easier to install.

The camera is equipped with a built-in heater with a thermostat.



SPECIFICATION

Standard:	TCP/IP
Sensor:	4 x 1/1.8 " Progressive Scan CMOS
Matrix size:	4 x 1.8 Mpx - 7.3 Mpx (total)
Scanning system:	Progressive
Resolution:	4096 x 1800 - 7.3 Mpx , 3840 x 1680 - 6.5 Mpx , 2880 x 1264 - 3.6 Mpx , 1280 x 560 - 0.7 Mpx , 1024 x 452 - 0.5 Mpx
Lens:	4 x 5.0 mm / F2.2
View angle:	180 ° (horizontal) 80 ° (vertical)
Range of IR illumination:	30 m
S/N ratio:	> 50 dB
RS-485 interface:	—
Image compression method:	H.265+ / H.265 / H.264+ / H.264 / MJPEG
Alarm inputs / outputs:	2 / 2
Audio:	<ul style="list-style-type: none">• External microphone input• Audio output• Bi-directional audio streaming support
Bitrate:	9 ... 9472 kbps @ H.265 24 ... 15616 kbps @ H.264
Main stream frame rate:	25 fps @ 7.3 Mpx
Network interface:	10/100 Base-T (RJ-45)

DELTA-OPTI Monika Matysiak; <https://www.delta.poznan.pl>
POL; 60-713 Poznań; Graniczna 10
e-mail: delta-opti@delta.poznan.pl; tel: +(48) 61 864 69 60

Network protocols:	HTTP, HTTPS, TCP, ARP, RTSP, RTP, UDP, SMTP, FTP, DHCP, DNS, DDNS, PPPoE, IPv4/IPv6, QoS, UPnP, NTP, Bonjour, 802.1x Radius, Multicast, ICMP, IGMP, SNMP
Memory card slot:	Micro SD memory cards up to 128GB support (possible local recording)
Mobile phones support:	Port no.: 37777 or access by a cloud (P2P) <ul style="list-style-type: none"> • Android: Free application gDMSS Plus • iOS (iPhone): Free application iDMSS Plus
Default IP address:	192.168.1.108
Default admin user / password:	admin / - The administrator password should be set at the first start
Web browser access ports:	80, 37777
PC client access ports:	37777
Mobile client access ports:	37777
Port ONVIF:	80
RTSP URL:	rtsp://admin:hasło@192.168.1.108:554/cam/realmonitor?channel=1&subtype=0 - Main stream rtsp://admin:hasło@192.168.1.108:554/cam/realmonitor?channel=1&subtype=1 - Sub stream
WEB Server:	Built-in
Max. number of on-line users:	20
ONVIF:	16.12
Main features:	<ul style="list-style-type: none"> • IVS analysis - crossing the line (tripwire), intrusion, abandoned/missing object • Heat map - the selection in the image by corresponding colors the areas with different traffic • WDR - 120 dB - Wide Dynamic Range • 3D-DNR - Digital Noise Reduction • BLC/HLC - Back Light / High Light Compensation • Possibility to change the resolution, quality and bit rate • Time mark and image description • Image rotation and mirror • Configurable: brightness, contrast, saturation • Privacy zones • Motion Detection • The device has a built-in heater
Power supply:	<ul style="list-style-type: none"> • PoE (802.3at), • 24 V AC / 1.1 A - Heater on
Power consumption:	< 25.5 W
Housing:	Compact, Metal
Color:	Black + White
Vandal-proof:	IK10
"Index of Protection":	IP67
Operation temp:	-40 °C ... 60 °C
Weight:	2.82 kg
Dimensions:	298 x 173 x 121 mm
Supported languages:	English
Manufacturer / Brand:	DAHUA
Guarantee:	3 years

PRESENTATION



DELTA-OPTI Monika Matysiak; <https://www.delta.poznan.pl>
POL; 60-713 Poznań; Graniczna 10
e-mail: delta-opti@delta.poznan.pl; tel: +(48) 61 864 69 60

Front view:



Side view:



Mounting side view:

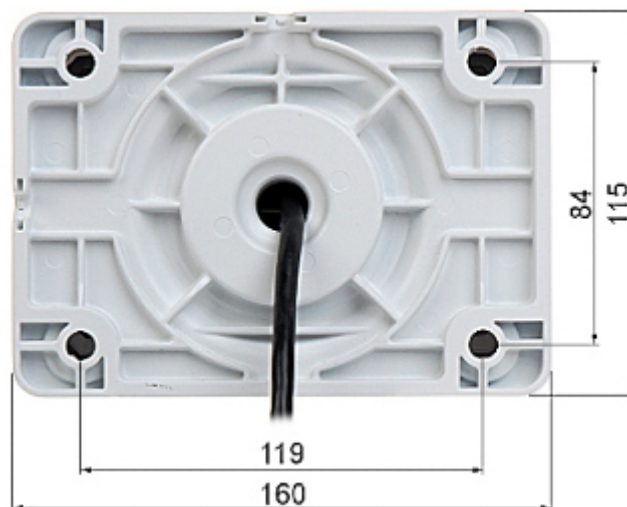

Bottom view (after remove the cover):



Connectors:



Connectors description:



Display modes:

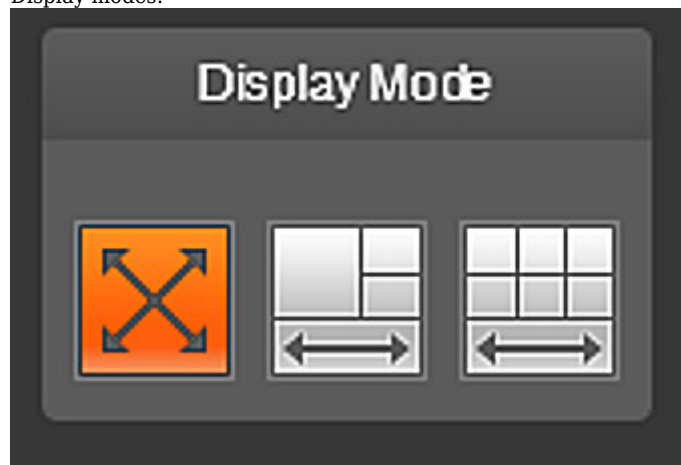

See how to initialize DAHUA cameras:

:

In the kit:

