

Code: DS-2CE56H0T-ITME(2.8mm)

## HD-TVI CAMERA **DS-2CE56H0T-ITME(2.8mm)** - 5 Mpx PoC.af Hikvision

Net: **63.70 EUR** Gross: **78.35 EUR**

Megapixel camera with Progressive scan CMOS sensor and HD-TVI. The HD-TVI interface allows to transmission of analog video signal via coaxial cable at resolutions up to 8 Mpx (4K). During transmission there are no delays and is maintained the original, high quality image.

In the case of video transmission using a twisted pair cable and matching transformers (balun), be aware of the possibility of signal reflections and interfering signals. Camera is according to IP67 Index of Protection norm.

The ability to power the camera via a coaxial cable according to the innovative PoC (Power over Coaxial) standard allows to eliminate the need for additional wiring to the unit.



### SPECIFICATION

Standard:	HD-TVI
Sensor:	Progressive Scan CMOS
Matrix size:	5 Mpx
Resolution:	<ul style="list-style-type: none"><li>• 2560 x 1944 - 5 Mpx,</li><li>• 2560 x 1440 - 4 Mpx,</li><li>• 1920 x 1080 - 1080p</li></ul>
Range of IR illumination:	20 m
IR illuminator power adjustment:	Automatic
Lens:	2.8 mm
View angle:	<ul style="list-style-type: none"><li>• 85 ° (manufacturer data)</li><li>• 82 ° (our tests result)</li></ul>
S/N ratio:	> 62 dB
Video output:	HD-TVI, 1 Vpp / 75 Ω - BNC socket
Main features:	<ul style="list-style-type: none"><li>• D-WDR - Wide Dynamic Range</li><li>• 2D-DNR - Digital Noise Reduction</li><li>• EXIR - high-efficiency infrared LEDs technology, which evenly covers the whole plan of both central vantage points of the scene as well as the corners</li><li>• AGC - Automatic Gain Control</li><li>• BLC - Back Light Compensation</li><li>• ICR - Movable InfraRed filter</li><li>• Auto White Balance</li><li>• Mirror - Mirror image</li><li>• Sharpness - sharper image outlines</li></ul>
OSD menu:	OSD menu available via recorder
Power supply:	PoC.af , 12 V DC / 340 mA

DELTA-OPTI Monika Matysiak; <https://www.delta.poznan.pl>  
POL; 60-713 Poznań; Graniczna 10  
e-mail: [delta-opti@delta.poznan.pl](mailto:delta-opti@delta.poznan.pl); tel: +(48) 61 864 69 60

Power consumption:	≤ 4.3 W
Housing:	Dome, Metal
Color:	White
"Index of Protection":	IP67
Vandal-proof:	—
Operation temp:	-40 °C ... 60 °C
Weight:	0.26 kg
Dimensions:	91 x 83 x 68 mm
Manufacturer / Brand:	Hikvision
SAP Code:	300611392
Guarantee:	<b>3 years</b>

## PRESENTATION

Camera is out from clamping ring:



Mounting side view:



Dimensions:

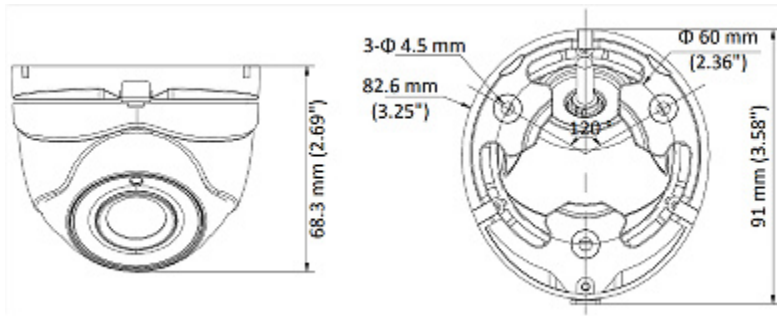

In the kit:

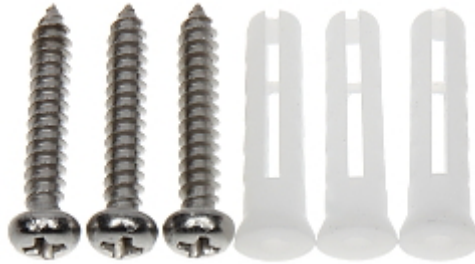

## OUR TESTS

Camera image at artificial illumination (about 30Lux):



Camera image at night conditions with internal built-in IR illuminator on:



Camera image at direct strong light opposite to camera:

