

Code: DS-2CE56H0T-VPITE(2.8mm)

HD-TVI VANDALPROOF CAMERA **DS-2CE56H0T-VPITE(2.8mm)** - 5 Mpx Hikvision

Net: **81.97 EUR** Gross: **100.82 EUR**



Megapixel camera with 1/3" Progressive Scan CMOS sensor and HD-TVI (High Definition Transport Video Interface).

The HD-TVI interface allows to transmission of analog video signal via coaxial cable at resolutions up to 5 Mpx. It enables the transmission of HD resolution images for even 500 m distance with keeping the low costs of the installation. During transmission there are no delays and is maintained the original, high quality image.

Housing construction allows to mount the camera to the ceiling and the wall (image is right oriented in both cases). Camera is according to IP67 Index of Protection norm.

SPECIFICATION

Standard:	HD-TVI
Sensor:	Progressive Scan CMOS
Matrix size:	5 Mpx
Resolution:	2560 x 1944 - 5 Mpx @ 20 fps , 2560 x 1440 - 3.7 Mpx @ 25 fps , 1920 x 1080 - 1080p @ 25 fps
Range of IR illumination:	20 m
IR illuminator power adjustment:	Automatic
Lens:	2.8 mm
View angle:	• 85 ° (manufacturer data) • 80 ° (our tests result)
IR illuminator support:	ICR - Movable InfraRed filter
Video output:	HD-TVI, 1 Vpp / 75 Ω
Main features:	<ul style="list-style-type: none">• 2D-DNR - Digital Noise Reduction• D-WDR - Wide Dynamic Range• EXIR - high-efficiency infrared LEDs technology, which evenly covers the whole plan of both central vantage points of the scene as well as the corners• AGC - Automatic Gain Control• BLC - Back Light Compensation• ICR - Movable InfraRed filter• Auto White Balance• Mirror - Mirror image• Sharpness - sharper image outlines
OSD menu:	✓

DELTA-OPTI Monika Matysiak; <https://www.delta.poznan.pl>
POL; 60-713 Poznań; Graniczna 10
e-mail: delta-opti@delta.poznan.pl; tel: +(48) 61 864 69 60

Power supply:	<ul style="list-style-type: none"> • PoC.af, • 12 V DC / 450 mA
Power consumption:	≤ 5.4 W
Housing:	Dome, Metal
"Index of Protection":	IP67
Vandal-proof:	IK10
Color:	White
Operation temp:	-40 °C ... 60 °C
Weight:	0.48 kg
Dimensions:	Ø 111 x 82 mm
Manufacturer / Brand:	Hikvision
SAP Code:	300611395
Guarantee:	3 years

PRESENTATION

Camera is out from clamping ring:



Mounting side view:



Dimensions:

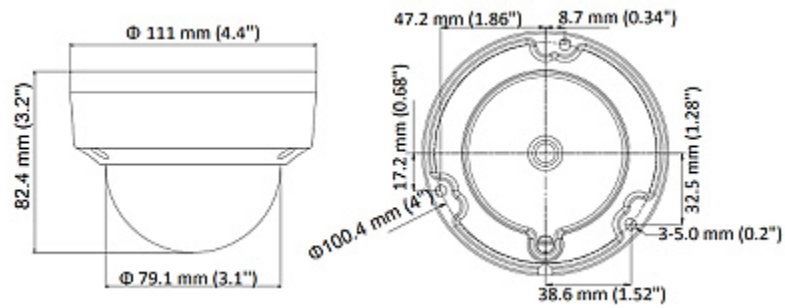

In the kit:



OUR TESTS

Camera image at artificial illumination (about 30Lux):



Camera image at night conditions with internal built-in IR illuminator on:



Camera image at direct strong light opposite to camera:

